

50 t CRAWLER CRANE



 186 kW

 50 t

 52.3 m

 MAX CAB

Stage V

50 t crawler crane 1100G

The most compact crawler crane in the SENNEBOGEN range convinces by combining three important crane attributes: compactness, flexibility and reliable performance.

Thanks to its compact dimensions, the 50 t crawler crane 1100 G is not only easy to transport, but also extremely maneuverable on narrow construction sites in civil engineering and industry. What's more, with its two 120 kN winches, it proves to be particularly powerful, lifting and traveling even more than other lifting equipment of comparable size, even with wide radii and long boom lengths - maximum reliability and efficiency guaranteed.

Reliable and durable:

The G series is characterized by robust components and an intelligent machine design according to state-of-the-art technological standards: high value retention, even with demanding continuous operation.

Flexible in use

Low space requirement combined with strong undercarriage traction for excellent off-road mobility - ideal for pick and carry applications. Benefit from the modular machine concept, tailored to your specific application.

Maintenance & service

This is made easy with standard components and easy-to-access maintenance and service points.

On site and ready to use fast

A small transport width and transport weight guarantee a cost-effective transport. Mounted on site in just a few steps thanks to the innovative SENNEBOGEN self-assembly system.

Maximum operator comfort and safety

The spacious Maxcab comfort cab offers maximum operator comfort for a relaxed and productive workday. This is complemented by stability and safety through a robust steel construction and durable mechanics, sensitive controls and numerous safety features.

The 50 t crawler crane 1100 G loading roof trusses.

Advanced. The **G** Series



LONG SERVICE LIFE, HIGH VALUE RETENTION

- /// Reliable and powerful thanks to its robust construction and high-quality components
- /// Temperature controlled cooling system designed and tested for heavy-duty applications and high ambient temperatures

SOPHISTICATED, STATE-OF-THE-ART TECHNOLOGY

- /// In the 6th Generation – decades of experience in designing and constructing crawler cranes

SIMPLE TO MAINTAIN AND SERVICE

- /// Technology that can be mastered and no over-engineering, easy access to all components

ENVIRONMENTALLY-FRIENDLY DRIVE TECHNOLOGY

- /// State-of-the-art engine, drive and emission systems in line with the latest technology standards (stage V)
- /// Large-scale pipes and valves for maximum efficiency

ECONOMICAL TRANSPORTATION THANKS TO COMPACT DIMENSIONS

It is not just with procurement and operating costs that companies can make cost-effective decisions and savings. Astute contractors know that simple and economical transportation between construction sites is an important factor, too.



Cost-efficient

All attachments and lattice boom segments are optimized for container transport



Compact

Transport width of base machine 3 m



Quick

The machine is ready for use on site in a short time thanks to the innovative self-assembly system.

MONEY SAVED – ASSEMBLE WITHOUT ADDITIONAL EQUIPMENT AND WITH LESS PERSONNEL

TIME AND COST EFFICIENT

Assembled on site in just a few steps, thanks to the innovative self-assembly system without the need for additional equipment.

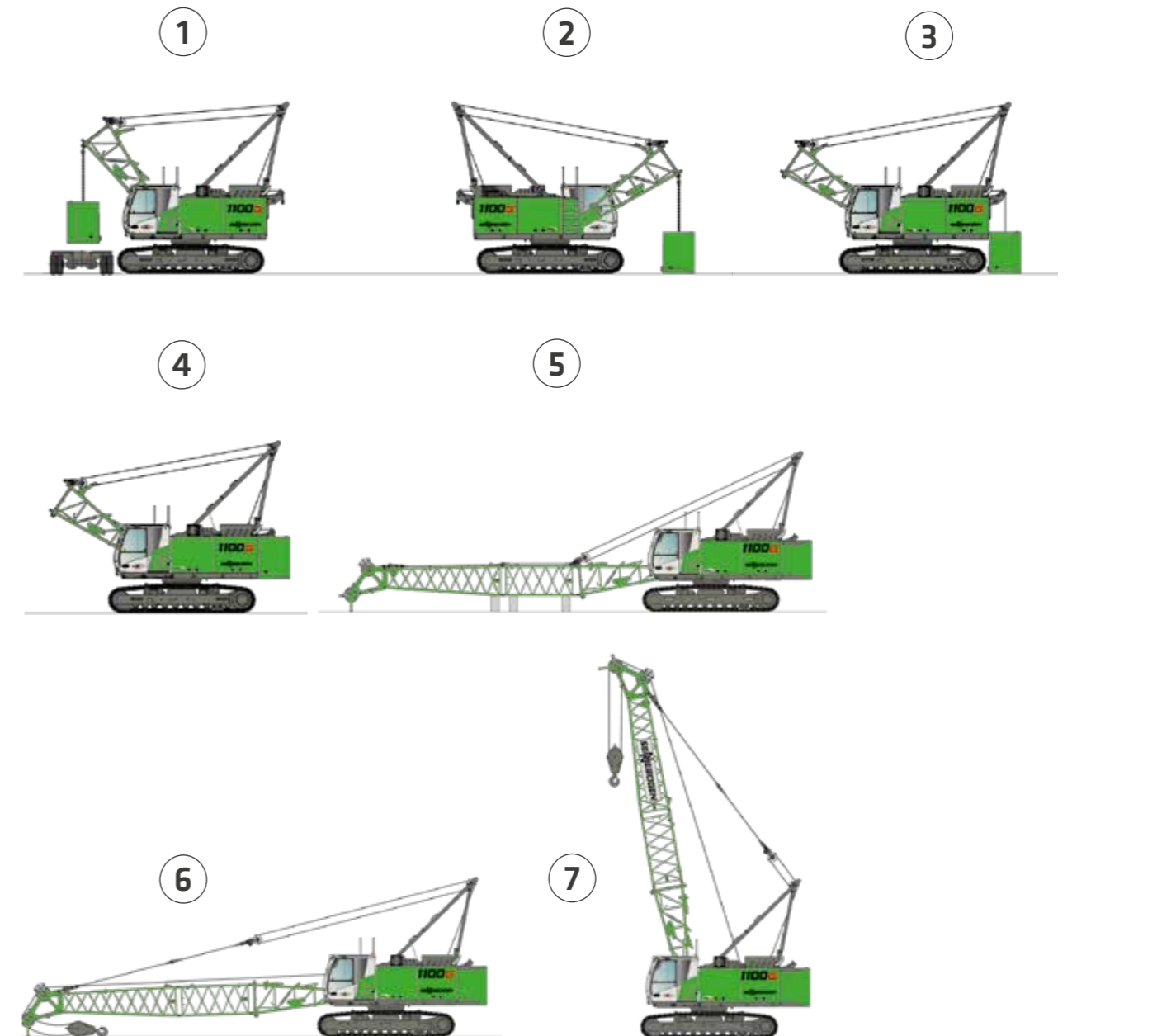

ROBUST: SAFE LIFTING ON INCLINES



FLEXIBEL: MOVE LOADS HORIZONTALLY & VERTICALLY



MAINTENANCE AND SERVICE MADE EASY



Sophisticated, state-of-the-art technology and optimal accessibility

KEEP IT SIMPLE. TECHNOLOGY THAT CAN BE MASTERED.

All service points are clearly arranged and easily accessible. The clear labeling of components makes finding your way around easy.



Reliable and practical technology makes life easier. We rely on hydraulics, electrics and electronics only where they provide the greatest benefit.



We make you happy, not reliant. With cost-effective components and fewer process steps, you can take care of the machine on your own.



At the central electrical distribution board, clearly arranged standard components simplify control and troubleshooting.

MODULAR DESIGN – VERSATILE SOLUTIONS

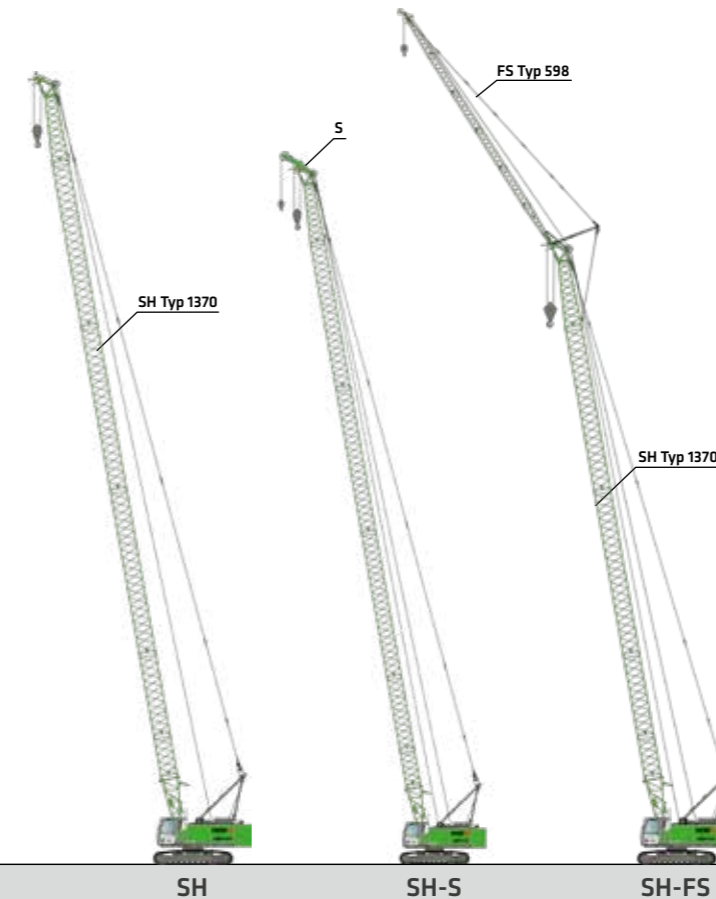

SH: Heavy main boom FS: Fixed jib S: Auxiliary jib

SPECIAL REQUIREMENTS? WE HAVE THE SOLUTION.

Tailored to your application, we realize the machine that suits you best. According to the tried and tested SENNEBOGEN modular system, the lattice boom can be variably designed from 10.3 to 52.3 meters.

What's more, different cab elevations and undercarriage options in mobile or crawler can be realized.



BETTER SAFETY. MAXIMUM COMFORT.



Everything in view

Excellent all-round and upward view thanks to large window panes, optionally with FOPS guard and bullet proof glass. The optionally available cab tilt of up to 20° enables direct eye contact with the load – for precise lifting work, even when working higher up. High-quality LED headlights and the standardized camera monitoring of the rear area and to the right side let you keep an excellent eye on all obstacles.

Intuitive controls

The intuitive SENCON control system shows all relevant information and possibilities for action and thus actively supports you in your work with the machine. Short paths for direct, sensitive control of all functions as well as ease of operation thanks to an optimized design of the buttons and switches.

Ergonomical – for your health

Operators spend many hours at their workplace. The back-friendly comfort seat, adjustable armrests, joysticks that sit comfortably in the hand, and the optimally arranged controls make daily work as easy as possible. Safe and comfortable access due to the tried-and-tested sliding doors incl. sliding window.

Pleasant indoor climate

Whether in warmer climates or sub-zero temperatures: The automatic heating/air conditioning with optimum air flow guarantees a pleasant indoor climate all year round. Noise reduction through sound-absorbing materials and design solutions – so that you can concentrate on what's important.



TECHNICAL DATA, EQUIPMENT

MACHINE TYPE

MODEL (TYPE) 1100 Crawler

ENGINE

TYPE **Stage V:**
Cummins B6.7 FR95885
Rated power: 168 kW/2200 rpm
Operating point standard: 188 kW/1800 rpm
Operating point ECO: 185 kW / 1650 rpm

Stage IIIa:
Cummins QSB6.7 FR96045
Rated power: 164 kW/2000 rpm
Operating point standard: 171 kW/1800 rpm
Operating point ECO: 161 kW / 1650 rpm

both:
direct injection, turbocharged, charge air cooling, reduced emissions

Idle / Stop Automatic

COOLING Water-cooled

DIESEL FILTER With water separator and heater

AIR FILTER Dry filter with integrated pre-separator, automatic dust discharge, main element and safety element, contamination indicator

FUEL TANK 450 l

ADBLUE TANK 45 l

ELECTRICAL SYSTEM 24 V

BATTERIES 2 x 150 Ah

OPTIONS Low temperature package

Electric fuel pump

UPPERCARRIAGE

DESIGN Torsion-resistant box design, precision crafted, bronze bushings for boom bearing arrangement, service-friendly concept, engine installed in the longitudinal direction

ELECTRICAL SYSTEM Central electrical distributor, battery disconnect switch

LIGHTING LED headlights for optimal lighting of the work area

COOLING SYSTEM 3-circuit cooling system with high cooling output, electrically regulated fan drive for cooling water, charged air and oil

SAFETY Camera monitoring of the area to the rear and the right side

OPTIONS Additional cameras
Sea climate resistant coating as corrosion protection

Customized paint finish

Low temperature package

Autom. central lubrication for equipment and live ring track

Pinion tooth lubrication

Ballast deposit system

Divided ballast

Uppercarriage railing (right and left side)

2 LED strobe lights at the rear



TECHNICAL DATA, EQUIPMENT

HYDRAULIC SYSTEM / HYDRAULICS

Multi-circuit hydraulic system for optimal function and capacity. Load-sensing / LUDV hydraulic system, pressure cut-off, load limit control, variable displacement piston pumps with individual control and energy-saving demand flow control. All movements can be run simultaneously.

DELIVERY RATE Up to 220 l / min

OPERATING PRESSURE Up to 330 bar

FILTRATION High-performance filtration with long change interval

HYDRAULIC TANK max. 550 l / 450 l (center of the sight glass)

CONTROL SYSTEM Proportional, precision hydraulic control of the movements, 2 servo joysticks for work functions, additional functions via switches and foot pedals – arranged clearly and ergonomically. High energy efficiency due to large-dimension hydraulic valves and lines. Measuring connections in the hydraulic circuits.

SAFETY Hydraulic circuits with safety valves

OPTIONS Bio-oil filling

SENNEBOGEN HydroClean micro-filter system (3 µm) with water separator

Hydraulic tank preheating

SLEWING DRIVE

GEARS Compact planetary gear with bent-axis hydraulic engine, integrated brake valves

SLEW BRAKE Spring-loaded multi-disk brake

SLEWING RING Large-scale, externally geared double-row slewing ring

SLEWING SPEED 0-4 rpm, three adjustable rotation speeds

OPTION Second slewing gear

CAB



CAB TYPE Maxcab

CAB FEATURES Comfortable operator cab with sliding door incl. sliding window, vibration damper, tinted safety glass, opening windshield, skylight, front and rear windshield wipers, 12 V/ 24 V connections, 2 headlights integrated into the front of the roof. Air-sprung comfort operator's seat with seat heating and headrest. Sunblind for skylight. Slew brake via foot pedal.

OPTIONS Cab can be tilted 20°

Hydraulically elevating cab type E270, can elevate up to 2.70 m and tilt by 20°, including grating next to cab with railing (screwed)

Auxiliary heating system with timer

Activated-carbon filter for cab

Bullet proof windshield

Bullet proof skylight

Sunblind for windshield

Protective roof grating

FOPS protective roof grating

Protective guards on the front

Radio with USB and SD connections, MP3 and Bluetooth® functions



TECHNICAL DATA, EQUIPMENT



Option: Auxiliary jib

EQUIPMENT

BOOM	Boom length SH 10.3 m – 52.3 m
DESIGN	Decades of experience and the latest computer simulations guarantee the greatest degree of stability and life-span
CRANE SAFETY	Latest generation of load moment monitoring with event recorder, clear operations panel showing all important data via the SENCON display, lifting limit switch, cable exit protection, pressure relief valves and pipe fracture protection
OPTIONS	Auxiliary jib: 8.5 t load capacity, 1-strand Fixed jib up to 18m

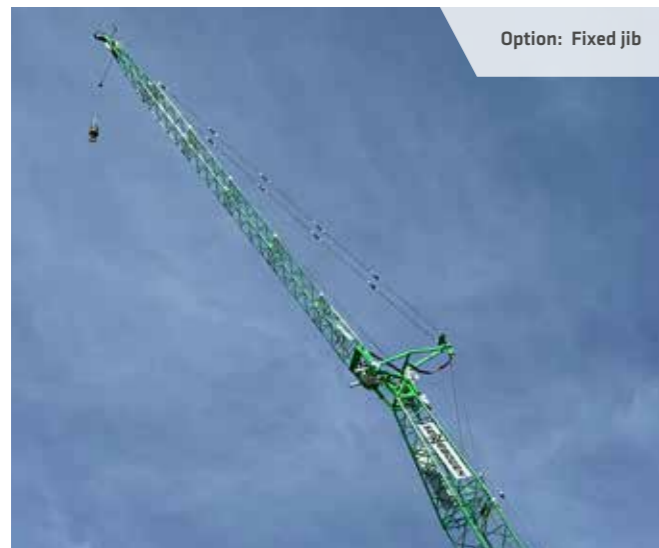

Option: Fixed jib

WINCH

The winches are driven via high-pressure-regulated adjustable hydraulic engines, so there is always optimal pulling force speed control. Hydraulic lowering brake valves for sensitive, wear-free braking. Strong oil bath planetary gears, low-maintenance.

Holding brakes are spring-loaded, maintenance-free, low-wear disc brakes running in the oil bath, oil-cooled

MAIN WINCH	120 kN tensile force (1st position), cable speed 0-125 m/min. (1st position), cable diameter 22 mm, usable cable length 220 m
BOOM ADJUSTMENT WINCH	Drive via bent-axis hydraulic engine with compact planetary gearbox, 52 kN tensile force, adjustment speed from 30° to 80° in approx. 40 seconds, cable diameter 14 mm
SAFETY BRAKE	Spring-loaded multi-disk brake
OPTION	2nd crane winch: 120kN tensile force (1st position), cable speed 0-125m/min. (1st position), cable diameter 22 mm, usable cable length 220 m



Option: Anemometer combined with flight warning light

TECHNICAL DATA, EQUIPMENT

UNDERCARRIAGE

DESIGN	T41/380 mit hydraulically adjustable track width. Stable welded design
DRIVE	Travel drive with axial piston hydraulic engine, directly attached automatically functioning brake valve and compact planetary gears on each running gear side, protected drive transmission
PARKING BRAKE	Spring-loaded multi-disk brake
TRAVELING GEAR	Maintenance-free tractor traveling gear with hydraulic track tension. Crawler with 700 mm triple grouser shoes
SPEED	0 - 1.5 km/h
OPTIONS	700 mm flat track shoes (transport width 3000 mm) 800 mm triple grouse shoes (transport width 3200 mm)

OPERATING WEIGHT

MASS	Approx. 50,000 kg with 10.3 m main boom, 18 t counter-weight, 60 t bottom hook block, 700 mm triple grouser shoes, 150 m hoist cable
NOTE	The operating weight varies with the equipment. Subject to technical changes.

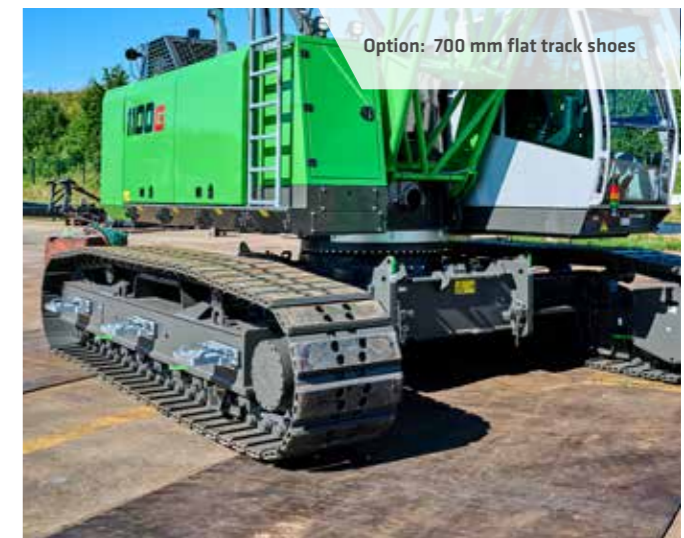

Option: 700 mm flat track shoes



Option: Mobile undercarriage*

CRANE EQUIPMENT



CRANE EQUIPMENT

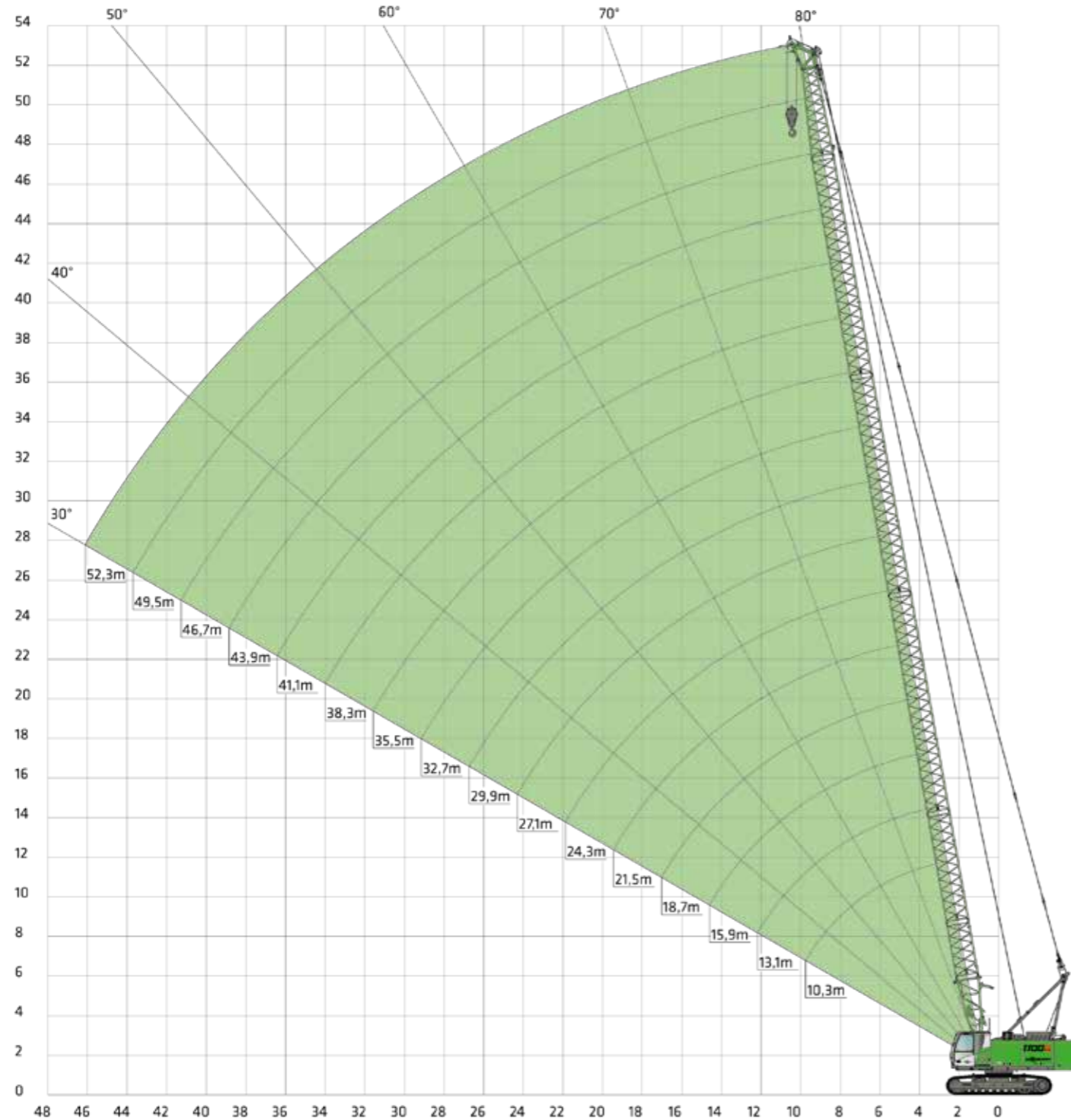

LOAD RATINGS



CRANE EQUIPMENT

RADIUS [m]	BOOM LENGTH [m]															
	10.3	13.1	15.9	18.7	21.5	24.3	27.1	29.9	32.7	35.5	38.3	41.1	43.9	46.7	49.5	52.3
3.0	50.0	49.0/3.6														
4.0	45.0	44.9	44.7	37.2/4.6												
5.0	36.0	35.8	35.6	34.0	32.5	28.2/5.5										
6.0	29.8	29.7	29.5	27.8	26.6	25.5	24.5	21.9/6.5								
7.0	24.1	24.0	23.9	23.3	22.5	21.6	20.8	20.2	19.5	18.0/7.5						
8.0	19.9	19.8	19.7	19.6	19.6	18.8	18.1	17.6	17.0	16.5	14.8/8.8					
9.0	16.5	16.8	16.7	16.7	16.6	16.5	16.0	15.6	15.1	14.6	14.1	12.8/9.9				
10.0	13.5	14.6	14.5	14.4	14.3	14.3	14.2	14.2	13.5	13.1	12.7	12.3				
11.0		12.9	12.7	12.7	12.6	12.5	12.4	12.4	12.3	11.8	11.5	11.2	10.8/11.1			
12.0		11.5	11.4	11.3	11.2	11.1	11.0	11.0	10.9	10.8	10.4	10.2	9.8	9.6/12.2		
13.0		10.9/12.4	10.2	10.2	10.1	10.0	9.9	9.9	9.7	9.7	9.6	9.3	9.0	8.8	8.3/13.5	
14.0			9.3	9.2	9.1	9.0	8.9	8.9	8.8	8.7	8.7	8.6	8.3	8.1	7.8	7.1/14.8
15.0			8.6/14.9	8.4	8.3	8.2	8.1	8.1	8.0	7.9	7.8	7.8	7.7	7.5	7.2	7.0
16.0				7.7	7.6	7.5	7.4	7.4	7.3	7.2	7.1	7.1	7.0	6.9	6.7	6.5
17.0				7.1	7.0	6.9	6.8	6.8	6.7	6.6	6.5	6.5	6.4	6.3	6.2	6.0
18.0				7.0/17.3	6.5	6.4	6.3	6.3	6.2	6.1	6.0	6.0	5.8	5.8	5.6	5.7
19.0					6.0	5.9	5.9	5.8	5.7	5.6	5.5	5.5	5.4	5.3	5.2	5.2
20.0						5.7/19.7	5.5	5.4	5.4	5.3	5.2	5.1	5.1	5.0	4.9	4.8
22.0							4.9	4.8	4.7	4.6	4.5	4.4	4.4	4.3	4.2	4.1
24.0								4.8/22.1	4.2	4.1	4.0	3.9	3.9	3.8	3.7	3.5
26.0									4.0/24.6	3.7	3.5	3.4	3.4	3.3	3.2	3.0
28.0										3.4/27.0	3.2	3.0	3.0	2.9	2.8	2.6
30.0											2.9/29.4	2.7	2.6	2.6	2.5	2.3
32.0												2.4/31.8	2.3	2.3	2.2	2.0
34.0													2.1	2.0	1.9	1.7
36.0														2.0/34.3	1.8	1.5
38.0															1.7/36.7	1.3
40.0																1.4/39.1
42.0																1.1
44.0															1.1/41.5	0.9
46.0																0.8
48.0																0.6
Number of falls	6	6	6	5	4	4	3	3	3	3	2	2	2	2	2	1

Tab.no.: 1100R-80/1978/18.0/11.16 SH

Notes:

1. The specified load ratings apply when the machine is on a firm and level surface.
2. The load ratings are given in tonnes and apply 360 degrees.
3. The load ratings take standards ISO 4305 Tab. 1+2 as well as the tilt angle method (tilt angle 4°) into account.
4. The weight of the load handling equipment (hooks, cable) should be deducted from the load ratings.
5. The load ratings apply for the maximum undercarriage track width of 3800 mm.
6. Load ratings must be limited or reduced in adverse conditions such as soft or uneven ground, slopes, wind, side loads, swinging loads, jolts or sudden stopping of loads, personnel and operators not experienced in handling loads.
7. Permissible cable pull per strand in crane mode for cable diameter 22 mm - 8,500 kg
8. Load ratings apply for the SH boom (boom assembly in accordance with the operating manual)
9. Load ratings apply for optimum boom assembly and a pulley head with plastic pulleys.

HOOKS



For 120 kN winches with a cable diameter of 22 mm

CAPACITY	WEIGHT	NUMBER OF FALLS AND MAXIMUM LOAD CAPACITY [kg]					
		6	5	4	3	2	1
10 t	200 kg						8,500
25 t 1-pulley	300 kg				25,000	17,000	8,500
40 t 2-pulley	350 kg		40,000	34,000	25,500	17,000	8,500
60 t 3-pulley	650 kg	50,000	42,500	34,000	25,500	17,000	8,500

OPTIONAL EQUIPMENT

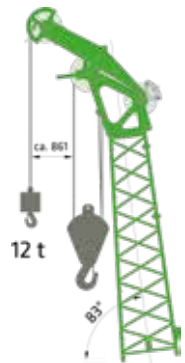

AUXILIARY JIB
1-strand, max. load capacity 8.5 t,
cable diameter 22 mm

TRANSPORT DIMENSIONS

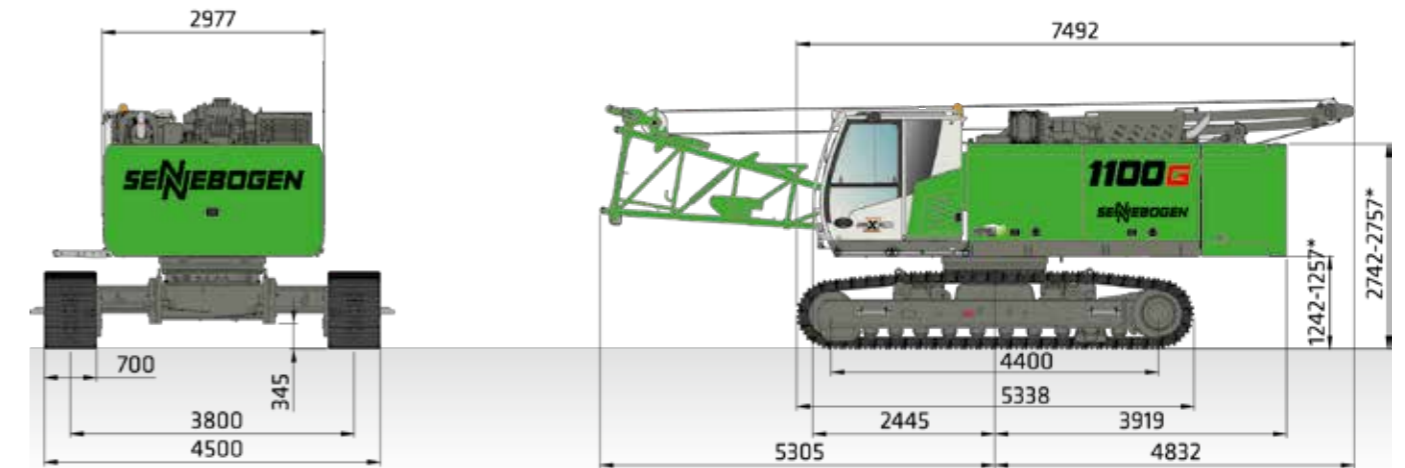

1100 G with 18 t counterweight, telescopic undercarriage T41/380, lower boom section, 2 x 12 t winch, approx. 48,400 kg

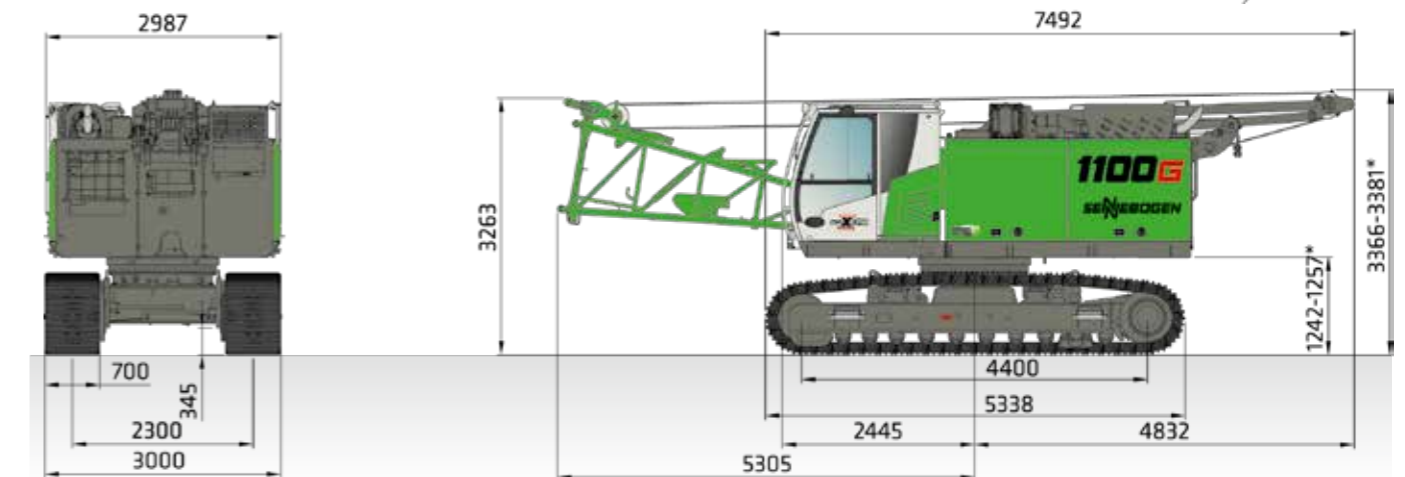
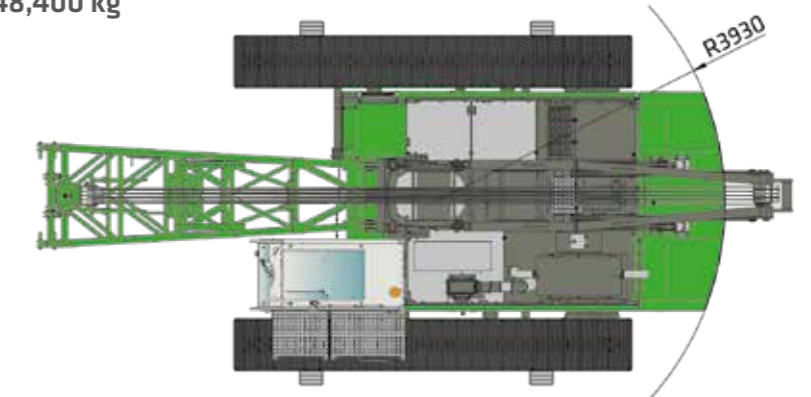

1100 G without counterweight, lower boom section, 2 x 12 t winch, approx. 30,400 kg

CRANE EQUIPMENT

TRANSPORT DIMENSIONS

TRANSPORT DIMENSIONS

LOWER BOOM SECTION 4.4 m TYPE 1370

i Weight: 830 kg

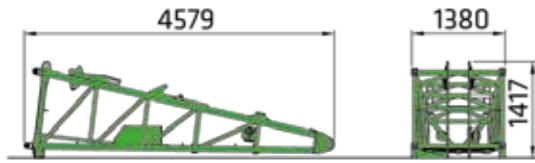

BOOM SECTION 2.8 m TYPE 1370

i Weight: 300 kg

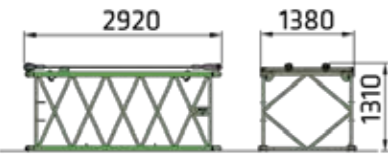

BOOM SECTION 5.6 m TYP 1370

i Weight: 490 kg

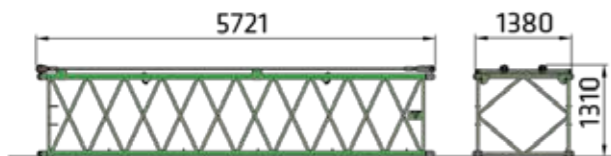

BOOM SECTION 11.2 m TYPE 1370

i Weight: 870 kg

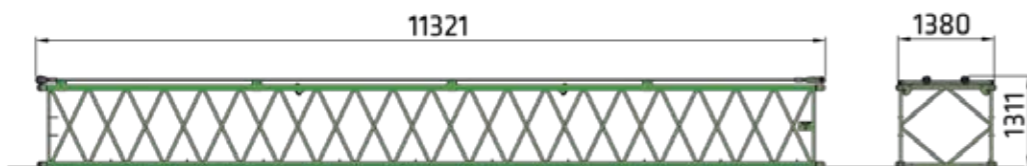

BOOM HEADPIECE 5.9 m TYPE 1370

i Weight: 1145 kg (steel pulleys)
960 kg (plastic pulleys)



AUXILIARY JIB

i Weight: 280 kg



TRANSPORT DIMENSIONS

COUNTERWEIGHT

i Weight: 18000 kg

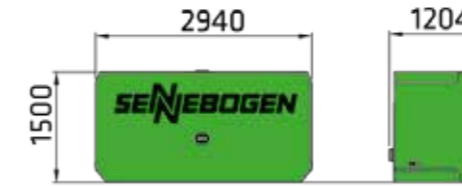

DIVIDED COUNTERWEIGHT (OPTION) TOP SECTION

i Weight: 8600 kg



BOTTOM SECTION

i Weight: 9400 kg

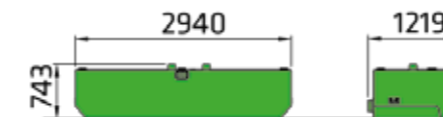

LOWER BOOM SECTION 3 m TYPE 598 (FIXED JIB)

i Weight: 330 kg



BOOM SECTION 3 m TYPE 598 (FIXED JIB)

i Weight: 120 kg

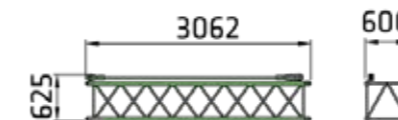

BOOM HEADPIECE 3 m TYPE 598 (FIXED JIB)

i Weight: 210 kg

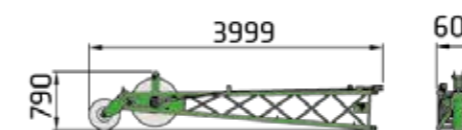

READ MORE



www.sennebogen.com/1100



Prefabricated parts assembly; Netherlands

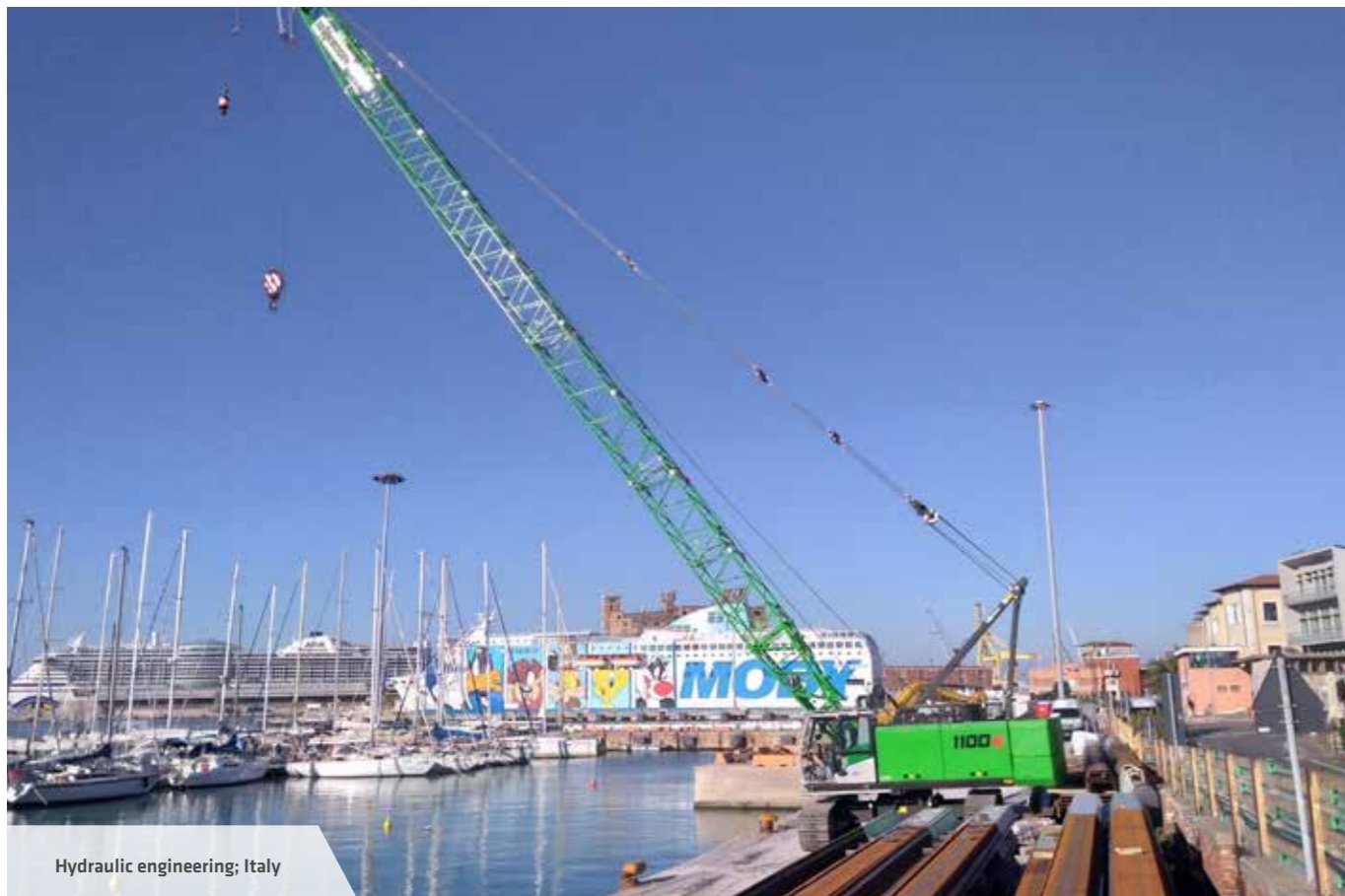

Hydraulic engineering; Italy

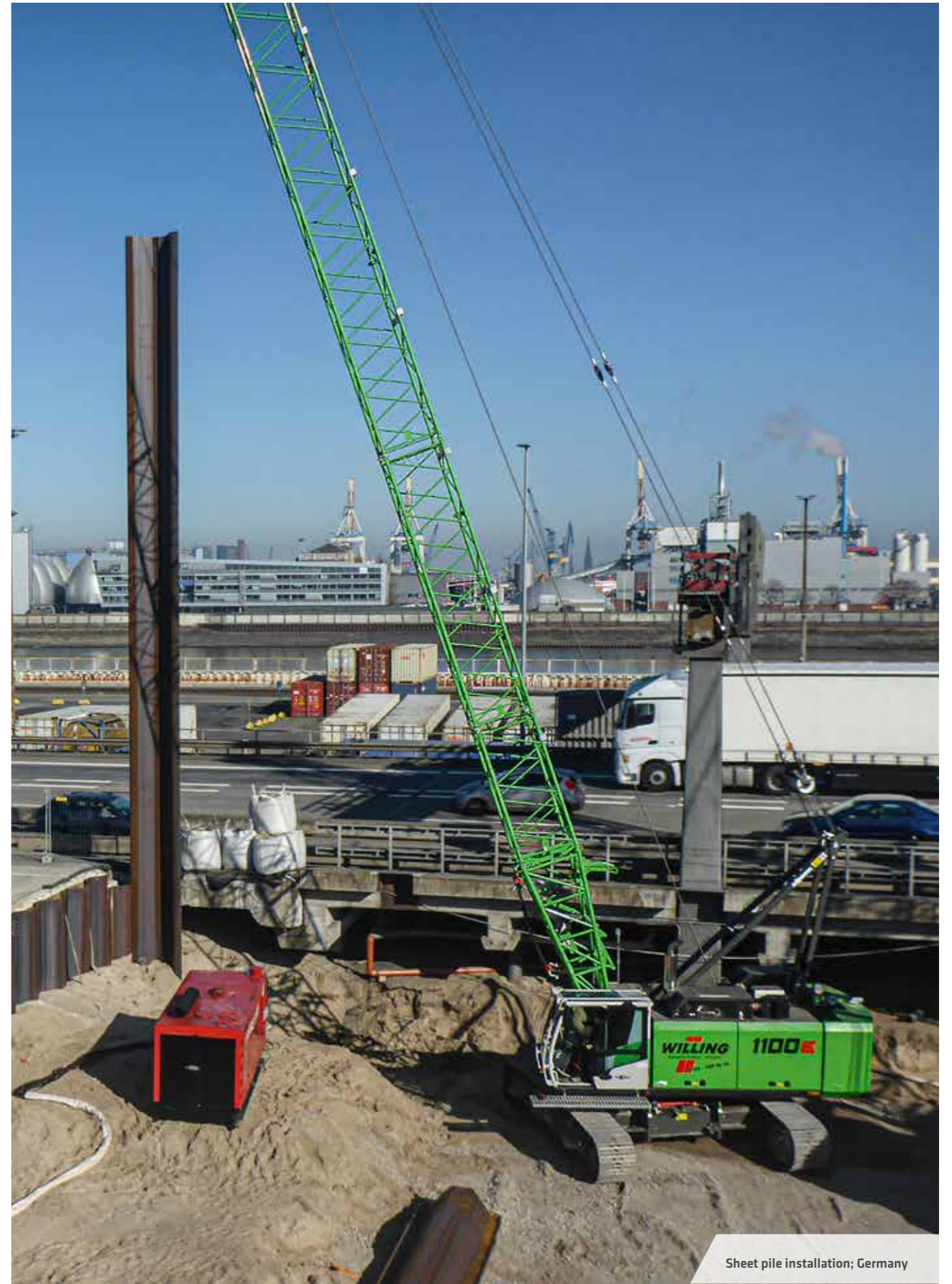

Sheet pile installation; Germany



SENNEBOGEN ACADEMY

Increase your knowledge because success is based on knowledge. In the SENNEBOGEN ACADEMY we place great importance on ensuring it flows powerfully.
 → www.sennebogen-academy.com



SERVICE AND MAINTENANCE

Comprehensive customer service. And supply of spare parts. Service is a TOP priority for us.
 → www.sennebogen.com/customer-service



SENtrack

Efficient fleet management with SENtrack: Use information that would otherwise stay hidden and increase your efficiency.
 → www.sennebogen.com/sentrack



RENTAL & USED

Discover the unique range of rental machines available from SENNEBOGEN Rental & Used. Find your rental machine here:
 → www.sennebogen-rental-used.com



MOVE BIG THINGS WITH US

over **71** years of experience

100 % family company

over **2200** experienced specialists worldwide

5 production plants in Germany

over **180** sales and service partners worldwide

5 different lattice boom crawler cranes



Telehandler 4-5,5 t	Balancer 130-300 t	Material handler 17-420 t	Duty cycle crane 13,5-300 t	Crawler crane 50-300 t	Telescopic crane 16-130 t	Port crane 300 t
------------------------	-----------------------	------------------------------	--------------------------------	---------------------------	------------------------------	---------------------

JOIN OUR OPERATORS' CLUB

The spotlight is on you and your machine! We focus on exclusive information, sharing experiences with other SENNEBOGEN operators as well as fun and enthusiasm.

All benefits here → www.sennebogen.com/operators-club



1100G

Order-no. 299127
1100-G-072310

This catalog describes machine models, the scope of equipment of individual models, and configuration options (standard equipment and optional equipment) of the machines delivered by SENNEBOGEN Maschinenfabrik GmbH. Machine illustrations may contain optional and supplementary equipment. Actual equipment may vary depending on the country to which the machines are delivered, especially in regard to standard and optional equipment. All product designations used may be trademarks of SENNEBOGEN Maschinenfabrik GmbH or other supplying companies, and any use by third parties for their own purposes may violate the rights of the owners.

Please contact your local SENNEBOGEN sales partner for information concerning the equipment variants offered. Requested performance characteristics are only binding if they are expressly stipulated upon conclusion of the contract. Delivery options and technical features are subject to change. All information is supplied without liability. Equipment is subject to change, and rights of advancement are reserved. © SENNEBOGEN Maschinenfabrik GmbH, Straubing, Germany. Reproduction in whole or in part only with written consent of SENNEBOGEN Maschinenfabrik GmbH, Straubing, Germany.



» sennebogen.com/1100

SENNEBOGEN
Maschinenfabrik GmbH
Hebbelstraße 30
94315 Straubing, Germany

➔ www.sennebogen.com

MOVE BIG THINGS

SALES SENNEBOGEN

Sales Crane Line

☎ +49 (0) 9421 / 540 - 146

✉ cranes@sennebogen.de

SPARE PARTS CENTER

Spare parts orders

✉ spareparts@sennebogen.de

AFTER SALES

Technical support

✉ service@sennebogen.de

