

Technical sheet :

2100VT



 **MANITOU**
HANDLING YOUR WORLD

Capacities		Metric	Imperial
Operating Capacity At 50% Tipping Load		1361 kg	3000 lb
Operating Weight		4021 kg	8865 lb
Unladen weight		3651 kg	8049 lb
Tipping capacity		2721 kg	5999 lb
Weight and dimensions			
Operating Weight - Approximate		4021 kg	8865 lb
Overall Operating Height - Fully Raised	h27	4026 mm	159 in
Height to Hinge Pin - Fully Raised	h28	3073 mm	121 in
Overall Height to Top of ROPS	h17	2045 mm	81 in
Dump angle at full height	a5	42 °	42 °
Dump height	h29	2300 mm	91 in
Overall length with bucket	l16	3543 mm	139 in
Dump reach - Full height	r6	927 mm	36 in
Rollback Angle at Full Height	a4	92 °	92 °
Seat to ground height	h30	965 mm	38 in
Overall width less bucket	b1	1674 mm	66 in
Ground clearance	m4	191 mm	8 in
Overall length - Less Bucket	l2	2743 mm	108 in
Clearance Radius - Front with Bucket	b18	2210 mm	87 in
Clearance Circle - Rear	wa1	1600 mm	63 in
Performances			
Travel Speed with Two-Speed Option - Maximum		15.30 km/h	10 mi/h
Travel speed (unladen)		10.30 km/h	6 mi/h
Wheels			
Transmission type		Hydrostatic	Hydrostatic
Engine			
Engine brand		Yanmar	Yanmar
Engine model		4TNV98C-NGL	4TNV98C-NGL
Engine norm		Stage V	Stage V
Gross Power (kW)		51.70 kW	52 kW
Net Power (kW)		51 kW	51 kW
Max. torque / Engine rotation		241 Nm / 1625 rpm	178 ft/lbs / 1625 rpm
Number of cylinders		4	4
Engine cooling system		Water	Water
Battery		12 V	12 V
Alternator - Ampere		100 A	100 A
Starter (kW)		3 kW	3 kW
Hydraulics			
Standard flow - Auxiliary hydraulics		86.50 l/min	23 US gpm
Auxiliary Hydraulic Pressure		239.59 bar	3475 PSI
High-Flow Auxiliary Hydraulics - Option		114 l/min	30 US gpm
High-Flow Auxiliary Hydraulics Pressure - Option		229.25 bar	3325 PSI
Tank capacities			
Fuel tank		143.80 l	38 US gal
Displacement		3.30 l	0.87 US gal

2100VT - Dimensional drawing

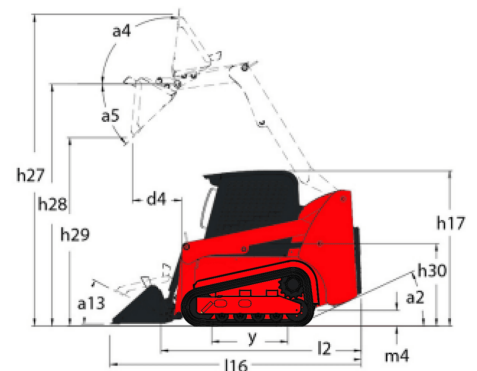
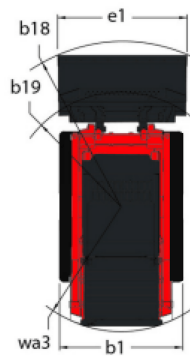



Head Office

B.P. 249 - 430 rue de l'Aubinière

44150 Ancenis Cedex - France

Tel: +33 (0)2 40 09 10 11 - Fax: +33 (0)2 40 09 10 97

www.manitou.com



This publication provides a description of the configuration versions and options for Manitou products, which may differ for equipment. The equipment presented in this brochure may be part of a series, as an option, or it may not be available, depending on the versions. Manitou reserves the right, at any time and without notice, to amend the specifications described and represented. The specifications provided do not bind the manufacturer. For more details, please contact your Manitou agent. This is not a contractually binding document. The presentation of the products is not contractually binding. List of specifications non-exhaustive. The logos as well as the visual identity of the company are owned by Manitou and cannot be used without authorisation. All rights reserved. The photos and diagrams contained in this brochure are only provided for consultation and information purposes.

MANITOU BF SA - Limited company with board of directors - Share capital: 39,668,399 euros - 857 802 508 RCS Nantes