

KOMATSU

WA270-8



Wheel loader

Engine power
115 kW / 153 HP @ 2000 rpm

Operating weight
12975 - 13525 kg

Bucket capacity
2.2 - 2.3 m³

WA270-8



Engine power

115 kW / 153 HP @ 2000 rpm

Operating weight

12975 - 13525 kg

Bucket capacity

2.2 - 2.3 m³

Increased fuel efficiency and environmental performance

Powerful and environmentally friendly

- EU Stage V engine
- Komatsu SmartLoader Logic
- Highly efficient hydrostatic drive line
- High efficiency buckets
- Adjustable idle shutdown



First-class comfort

- New, air-suspended operator seat
- Large multifunctional monitor
- Low-noise design
- Rear-view camera system
- Komatsu short lever steering (K-SLS) (option)

PZ-linkage

- Combines advantages of Z-bar linkage with parallel lift
- Fast pallet handling
- Excellent break-out force and easy bucket fill
- High tilt forces give perfect control of heavy attachments

Responsive hydrostatic drive line (HST)

- Instant response for fast loading cycles
- Easy control in confined areas
- Advanced traction control system for best traction and minimized tyre wear
- Top speed selection for increased safety

Easy maintenance

- Wide-core radiator with auto reverse fan
- Improved gull-wing type engine doors
- Factory fitted automatic lubrication system (option)

Komtrax

- Komatsu Wireless Monitoring System
- 4G mobile communications
- Integrated communication antenna
- Increased operational data and fuel savings



A maintenance program
for Komatsu customers



Highly efficient hydrostatic drive line

The electronically controlled variable pump and 2-motor system allow highly efficient and powerful operation. At low speeds both motors are engaged to provide highest torque. Bucket filling and scooping are easy, as maximum rim pull is provided from zero travel speed. At high speeds, a clutch cuts off the low speed motor to eliminate drag and achieve excellent fuel efficiency.

Komatsu SmartLoader Logic

The WA270-8 provides Komatsu SmartLoader Logic, a fully automatic engine control system. Without interfering with normal operations, this technology acquires data from various sensors in the vehicle and delivers optimal engine torque for each work phase. It limits torque during less demanding operations and reduces fuel usage without decreasing production.

More fuel-saving technology

The WA270-8's Eco-gauge displays active recommendations on the cab's monitor to help you maximise those fuel savings. For added fuel economy, and to prevent wasted hydraulic flow when working or steering, the hydraulic system's new variable piston pump delivers the exact amount of oil required for all machine movements.

Powerful and environmentally friendly

Komatsu EU Stage V

The Komatsu EU Stage V engine is productive, dependable and efficient. With ultra-low emissions, it provides a lower environmental impact and a superior performance to help reduce operating costs and lets the operator work in complete peace of mind.



Heavy-duty aftertreatment

The aftertreatment system combines a Komatsu Diesel Particulate Filter (KDPF) and Selective Catalytic Reduction (SCR). The SCR injects the correct amount of AdBlue® into the system at the proper rate to break down NOx into water (H₂O) and non-toxic nitrogen gas (N₂). NOx emissions are reduced by 80% vs. EU Stage IIIB engines.

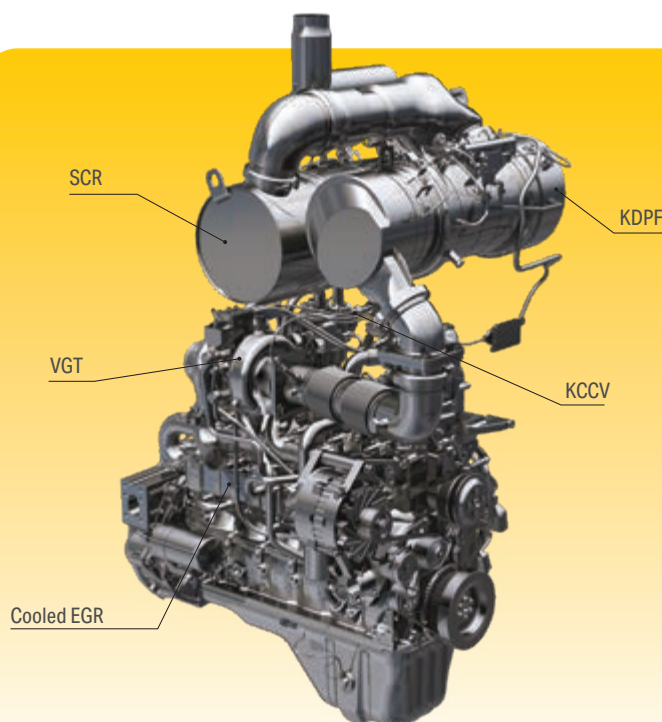
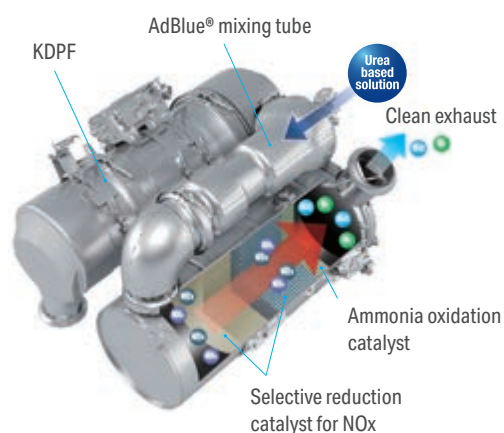

High-Pressure Common Rail (HPCR)

To achieve complete fuel burn and lower exhaust emissions, the heavy-duty High-Pressure Common Rail fuel injection system is computer controlled to deliver a precise quantity of pressurised fuel into the redesigned engine combustion chamber by multiple injections.

Exhaust Gas Recirculation (EGR)

Cooled EGR is a technology well-proven in current Komatsu engines. The increased capacity of the EGR cooler now ensures very low NOx emissions and a better engine performance.

Komatsu Closed Crankcase Ventilation (KCCV)

Crankcase emissions (blow-by gas) are passed through a CCV filter. The oil mist trapped in the filter is returned back to the crankcase while the filtered gas is returned to the air intake.

Variable Geometry Turbo (VGT)

The VGT provides optimal airflow to the engine combustion chamber under all speed and load conditions. Exhaust gas is cleaner, fuel economy is improved while machine power and performance are maintained.

Multipurpose PZ-linkage

One machine for all applications

The PZ = "parallel Z-bar" has the added advantage of parallel lift for pallet moving and high tilt forces to handle large attachments. The PZ-linkage turns your WA270-8 into a true multipurpose machine ready to take on any job.

Parallel lift for fast pallet handling

With the parallel lift PZ-linkage, pallet moving becomes easy. The parallelism has been optimized for safe work over the entire lifting range. The excellent visibility of the front attachment allows an easy pick-up of pallets and precise work when loading onto trucks.

Easy bucket fill

The superior break-out force of the WA270-8 turns loading into a child's play, even for an untrained operator. More experienced workers will also appreciate this feature, particularly when working with high density material such as heavy soil or aggregate.

Controlled work with heavy attachments

With the PZ-linkage design, tilting forces reach an optimal level, especially at maximum boom height. This is essential for controlling large attachments such as high dump buckets or other oversized buckets. The WA270-8 is the ideal choice when working with heavy attachments.

Best in class dumping height

The long lifting frame allows the best in class dumping height of 2.95 m with a straight tipping load of 10.3 tonnes (with 2.3 m³ flat bottom bucket, measured to the cutting edge). With this working range, loading high feeders or trucks becomes easy and fast.





Instant response for fast loading cycles

The Komatsu HST drive line features exceptional responsiveness that results in quick acceleration and fast forward/reverse changes. The drive line reacts to the operator's command without any time lag and instantly provides torque at the wheels. This allows for fast loading cycles and higher productivity.

Advanced traction control system (K-TCS)

The Komatsu Traction Control System (K-TCS) controls the HST pump, motor and engine to optimize traction automatically depending on work conditions. The provided rim pull can be set to 6 different levels to prevent spinning wheels on any ground conditions, even when operating on snow (S-mode). Constant traction increases productivity and reduces tyre wear and cost.

Easy control in confined areas

The self braking effect of the HST drive line slows down the machine when the accelerator pedal is released. Uncontrolled rolling is prevented, and safety is greatly improved, especially when working in confined spaces or inside industrial buildings. In addition, brake wear is practically eliminated.

Top speed selection for increased safety

The variable shift control allows setting the top speed for improved safety and precision. The top speed can be adjusted to the working conditions: max speed for fast travelling between jobsites, reduced speed to increase the safety when working on jobsites with high traffic or for working in confined spaces. In position 1, the speed can be continuously adjusted between 1 and 13 km/h with the fine control. This allows constant low driving speeds that are perfectly adjusted to applications such as lawn mowing or milling jobs.



Variable shift control dial with new creeping speed range (left) and variable traction control system switch (right)

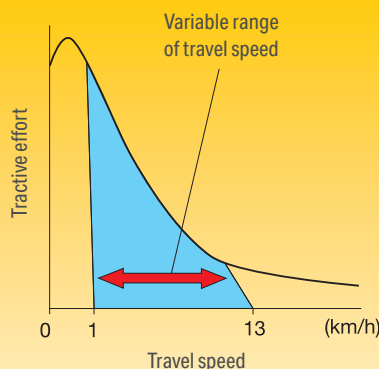

Responsive hydrostatic drive line (HST)



First-class comfort

New, fully air-suspended operator seat

The wide spacious cab features a new, fully air-suspended operator seat with a high back, fully adjustable, standard heated seat for improved comfort. A seat ventilation is optionally available to maximise comfort.

PPC multi-function lever

The PPC multi-function lever with electronic control for 3rd spool (EPC) is standard. It includes a forward-neutral-reverse switch for quick and easy travel. Third spool attachments can be set to continuous or proportional control via the monitor panel, to let the operator control the boom, bucket and attachment with a single lever.



Improved operator convenience

With increased in-cab storage space, an auxiliary input (MP3 jack) and 12 V and 24 V power supply, the cab offers maximum convenience. The automatic air conditioner allows the operator to easily and precisely set the cab's atmosphere.

Rear view camera

A standard fitment camera gives an exceptionally clear view of the rear work zone on the wide-screen colour monitor panel. The low profile camera is adjustable and integrated into the engine hood's shape.

Komatsu short lever steering (K-SLS) (option)

The new finger-type joystick steering allows more accurate steering by the operator who can now sit relaxed in the new air-suspended and fully adjustable seat to control the machine with no big effort needed for frequent steering. Less fatigue and work in a perfectly adapted operating position will improve concentration and the quality and efficiency of the work.



Auxiliary input (MP3 jack)



Hot and cool box



Komatsu short lever steering (K-SLS) (option)



PPC multi-function lever





Lower operating costs

Komatsu ICT contributes to the reduction of operating costs by assisting to comfortably and efficiently manage operations. It raises the level of customer satisfaction and the competitive edge of our products.

Large TFT colour monitor

A large user-friendly colour monitor enables safe, accurate and smooth work. Multilingual and with all essential information available at a glance, it features simple and easy-to-operate switches and multifunction keys that provide fingertip access to a wide range of functions and operating information.

Eco guidance

The monitor panel displays instant guidance messages to help promote energy saving, and the Eco-gauge indicates the actual fuel consumption: keep the Eco-gauge in the green zone for better fuel efficiency. To further improve savings, logs can be consulted for operations, Eco guidance and fuel consumption. The information is available in Komtrax and can be used for operator trainings and jobsite optimisation.



Information at a glance: basic dashboard LCD monitor



A multifunction monitor displays and controls a wealth of operational and maintenance information



Eco guidance supports energy saving in real time (e.g. avoid long time engine idling)

Information & communication technology



Knowledge

You get quick answers to basic and critical questions about your machines – what they're doing, when they did it, where they're located, how they can be used more efficiently and when they need to be serviced. Performance data is relayed by wireless communication technology (satellite, GPRS or 4G depending on model) from the machine to a computer and to the local Komatsu distributor – who's readily available for expert analysis and feedback.

Convenience

Komtrax enables convenient fleet management on the web, wherever you are. Data is analysed and packaged specifically for effortless and intuitive viewing in maps, lists, graphs and charts. You can foresee eventual maintenance issues and required spare parts, and troubleshoot a problem before Komatsu technicians arrive on site.



The way to higher productivity

Komtrax uses the latest wireless monitoring technology. Compatible on PC, smartphone or tablet, it delivers insightful and cost saving information about your fleet and equipment, and offers a wealth of information to facilitate peak machine performance. By creating a tightly integrated web of support it allows proactive and preventive maintenance and helps to efficiently run a business.

Power

The detailed information that Komtrax puts at your fingertips 24 hours a day, 7 days a week gives the power to make better daily and long-term strategic decisions – at no extra cost. Problems can be anticipated, maintenance schedules customised, downtime minimised and machines kept where they belong: working on the jobsite.



Easy maintenance



Easy access to service points

For easy and safe opening the gull-wing doors are supported by gas springs. The large doors give a convenient access from ground level to all daily service points. With long service intervals and filters collected in a centralised arrangement, machine downtime is reduced to a minimum.

Komatsu Care

Komatsu Care is a maintenance program that comes as standard with your new Komatsu machine. It covers factory-scheduled maintenance, performed with Komatsu Genuine parts by Komatsu-trained technicians. Depending on your machine's engine, it also offers extended coverage of the Komatsu Diesel Particulate Filter (KDPF) and of the Selective Catalytic Reduction (SCR). Please contact your local Komatsu distributor for terms and conditions.



Wide core radiator with auto reverse fan

A wide core radiator prevents clogging even when working in a dusty environment. To minimise manual cleaning, a reversible fan blows dust out, automatically or on demand. The "automatic reverse" function allows to set the cleaning length and the time between cleaning to adjust perfectly to the working conditions.

Equipment Management and Monitoring System (EMMS)

The large high resolution monitor panel displays various machine information and allows for multiple settings. The "Operation Records" menu shows records of the average fuel consumption, idling hours, and other features. Abnormality codes are clearly displayed and stored to alert you and simplify troubleshooting. The monitor also provides for advanced monitoring of the system parameters through the Service Mode to aid in troubleshooting and reduce downtime.



AdBlue® tank

The AdBlue® tank is located on the right hand side of the machine behind a ladder for easy access.

Diesel particulate filter regeneration

No interruption or extension of daily work is required to regenerate the diesel particulate filter system. Due to its superior Komatsu technology, KDPF regeneration takes place automatically, at any time.





Basic maintenance screen



Aftertreatment device regeneration screen for the KDPF



AdBlue® level gauge and refill guidance



Tailored solutions



Working gear division

Komatsu wheel loaders combined with a wide range of genuine Komatsu attachments provide the perfect solution for any industry sector. For special applications our "Working Gear" division offers purpose-built machines and attachments. The tailor made solutions allow high performance and outstanding reliability even under toughest conditions.

Waste handling

We adapt our wheel loaders to the different conditions that exist on waste handling job sites. Along with heavy duty attachments, we offer solutions to protect your machine against damage.

Agriculture

Simple handling, reliability and comprehensive safety features make Komatsu "agriculture" wheel loaders the ideal tools for contractors or large farms, for loading or for material handling. They are fitted with robust protection and safety equipment to provide perfect protection for both operator and machine.

Designed and built by Komatsu

The engine, hydraulics, power train, front and rear axles are original Komatsu components. All these components are subject to the highest quality standards right down to the smallest screw. All components are fully co-ordinated with one another, thus offering the maximum efficiency and reliability.

Heavy-duty axles

The heavy-duty axles allow exceptional service life even under the toughest working conditions. As standard, the WA270-8 is equipped with torque proportional differentials for work on good ground conditions such as on concrete yards or roads. The optional limited slip differentials are most suitable for soft and slippery ground like sand or wet soil.

HST drive line with overrun protection

The hydrostatic drive line is equipped with an overrun protection that electronically limits the top speed when driving downhill and thus ensures the long service life of the power train and the drive line system.

Wet multi-disc service brake

The multi-disc service brake is encapsulated and runs in an oil bath. The brake stays clean and operates at low temperature for increased service intervals and a long lifetime.



Robust torsion-resistant main frame

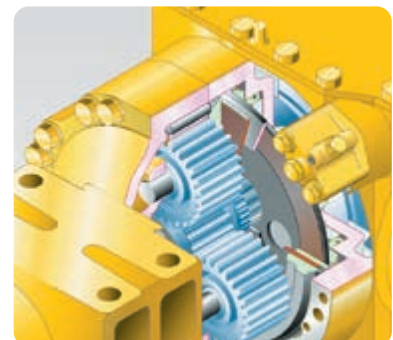

Wet multi-disc service brake

Buckets and attachments



High efficiency bucket range

The Komatsu high efficiency buckets enable easier bucket fill and significantly higher fill factors, contributing to more efficiency and less fuel consumption. They feature a longer bottom for more bucket content, a wider opening for an easier fill and a new rear shape that enables material to flow easily into the bucket. Their rounded sides give them a higher fill factor, and an integrated spill guard protects the bucket linkage.

High efficiency flat bottom buckets

The flat bottom bucket is used for soft grounds applications that require occasional grading passes, easily performed with the bucket's rear edge. This one-piece bottom bucket type is also suitable for earthmoving applications and for loading adhesive material.

High efficiency raised bottom buckets

The raised bottom bucket is suitable for hard surfaces applications with a high digging ratio. It excels with its outstanding penetration and break-out performance, together with good material retention. The combination of a rounded back side and convex side walls results in high bucket fill factors and minimal spillage during material transport.



Specifications

Engine

Model	Komatsu SAA6D107E-3
Type	Common rail direct injection, water-cooled, emissionised, turbocharged, after-cooled diesel
Engine power	
at rated engine speed	2000 rpm
ISO 14396	115 kW / 153 HP
ISO 9249 (net engine power)	111 kW / 149 HP
No. of cylinders	6
Bore × stroke	107 × 124 mm
Displacement	6.69 l
Battery	2 × 110 Ah
Alternator	90 A
Air-filter type	Dry-air filter with automatic dust emission and preliminary purification including a dust display
Fuel	Diesel fuel, conforming to EN590 Class 2/Grade D. Paraffinic fuel capability (HVO, GTL, BTL), conforming to EN 15940:2016

Transmission

Drive system	Electronically controlled hydrostatic transmission, switchable in all directions under full power. Fixed ratio gearbox. Variable speed limiter.
Hydrostatic pump	1 variable piston pump
Hydrostatic motor	2 variable piston motors
Speed ranges (forwards/backwards)	4/4

Max. travel speeds (forwards/backwards) (tyres 20.5 R25)

1. speed range	1-13 km/h
2. speed range	13 km/h
3. speed range	19 km/h
4. speed range	38 km/h

Chassis and tyres

System	4-wheel drive
Front axle	Komatsu HD axle, semi-floating, fixed type, TPD-differential (LSD-differential optional)
Rear axle	Komatsu HD axle, semi-floating, centre-pin support, 20° swing angle, TPD-differential (LSD-differential optional)
Reduction gear	Spiral bevel gear
Differential	Straight bevel gear pair
Final drive	Planetary gear in oil bath
Tyres	20.5 R25 (standard)

WA270-8E0

Brakes

Operating brakes	Completely hydraulic dual-circuit system, running in oil bath, multi-disc brakes on all wheels, service-free
Parking brake	Operated electronically, running in oil bath, multi-disc brake, service-free
Emergency brake	Uses the parking brake

Hydraulic system

Type	Komatsu CLSS (Closed Centre Load Sensing System)
Hydraulic pump	Variable piston pump
Working pressure (max.)	320 kg/cm ²
Maximum pump flow	150 l/min
No. of boom/bucket cylinders	2/1
Bore diameter × stroke	
Boom cylinder	110 × 717 mm
Bucket cylinder	140 × 480 mm
Hydraulic control lever	Servo-controlled, single lever
Hydraulic cycle with rated load bucket filling	
Raise time	6.0 s
Lowering time (empty)	3.2 s
Dumping time	2.0 s

Steering system

System	Articulated frame steering
Type	Completely hydraulic power steering
Steering angle to either side	40°
Steering pump	Piston pump
Working pressure	210 kg/cm ²
Pumping capacity	150 l/min
No. of steering cylinders	2
Bore diameter × stroke	70 × 453 mm

Cabin

Two-door SpaceCab™ in conformity with ISO 3471 with ROPS (roll over protective structure) in conformity with SAE J1040c and FOPS (falling object protective structure) in conformity with ISO 3449. The air-conditioned pressurised cabin is mounted upon hydrobearings and is noise dampened.

Service refill capacities

Cooling system	33.3 l
Fuel tank	186 l
Engine oil	23 l
Hydraulic system	80 l
Axle front	18.5 l
Axle rear	18 l
Transfer	7 l
AdBlue® tank	14 l

Environment

Engine emissions	Fully complies with EU Stage V exhaust emission regulations
Noise levels	
LwA external	104 dB(A) (2000/14/EC Stage II)
LpA operator ear	68 dB(A) (ISO 6396 dynamic test)
Vibration levels (EN 12096:1997)	
Hand/arm	≤ 2.5 m/s ² (uncertainty K = 0.20 m/s ²)
Body	≤ 0.5 m/s ² (uncertainty K = 0.11 m/s ²)
Contains fluorinated greenhouse gas HFC-134a (GWP 1430). Quantity of gas 1.0 kg, CO ₂ equivalent 1.43 t.	

Bucket selection guide (direct)

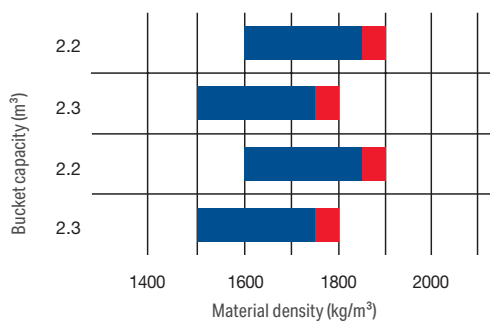
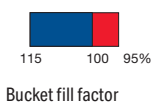

- Bucket with flat bottom with teeth (C46)
- Bucket with flat bottom with BOC (C47)
- Bucket with raised bottom with teeth (C14)
- Bucket with raised bottom with BOC (C15)

Bucket selection guide (QC)

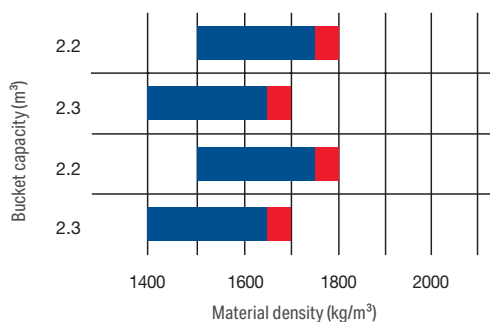
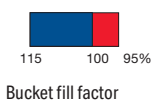

- Bucket with flat bottom with teeth (C76)
- Bucket with flat bottom with BOC (C77)
- Bucket with raised bottom with teeth (C84)
- Bucket with raised bottom with BOC (C85)

Dimensions and performance figures

Measurements and working specifications

Bucket type	Bucket with flat bottom				
		w. teeth	w. BOC	w. teeth	w. BOC
Bucket mount (direct/quick-coupler)		direct	direct	QC	QC
Bucket capacity (heaped, ISO 7546)	m³	2.2	2.3	2.2	2.3
Sales code		C46	C47	C76	C77
Material density	t/m ³	2.00	1.90	1.85	1.75
Bucket weight	kg	1200	1209	1164	1173
Static tipping load, straight	kg	10180	10107	9385	9316
Static tipping load, 40° articulated	kg	8852	8788	8115	8054
Break-out force hydraulic	kN	127	120	106	101.2
Lifting capability hydr. at ground level	kN	118	118	117	118
Operating weight	kg	13166	13175	13517	13526
Turning radius at corner of tyres	mm	5240	5240	5240	5240
Turning radius at bucket edge	mm	5878	5825	5944	5890
a Reach at 45°	mm	1133	1000	1292	1158
b Dumping height at 45°	mm	2773	2895	2629	2750
c Hinge pin height	mm	3965	3965	3965	3965
d Height top edge of bucket	mm	5185	5185	5360	5360
e Digging depth	mm	125	150	115	140
f Max. loading height at 45°	mm	3680	3680	3680	3680
A Overall length, bucket grounded	mm	7658	7497	7865	7704
B Wheel base	mm	2900	2900	2900	2900
C Bucket width	mm	2550	2540	2550	2540
D Width over tyres	mm	2470	2470	2470	2470
E Track width	mm	1930	1930	1930	1930
F Ground clearance	mm	465	465	465	465
H Overall height	mm	3200	3200	3200	3200

All measurements with tyres 20.5 R25 & with add. counterweight.
BOC: bolt-on cutting edge

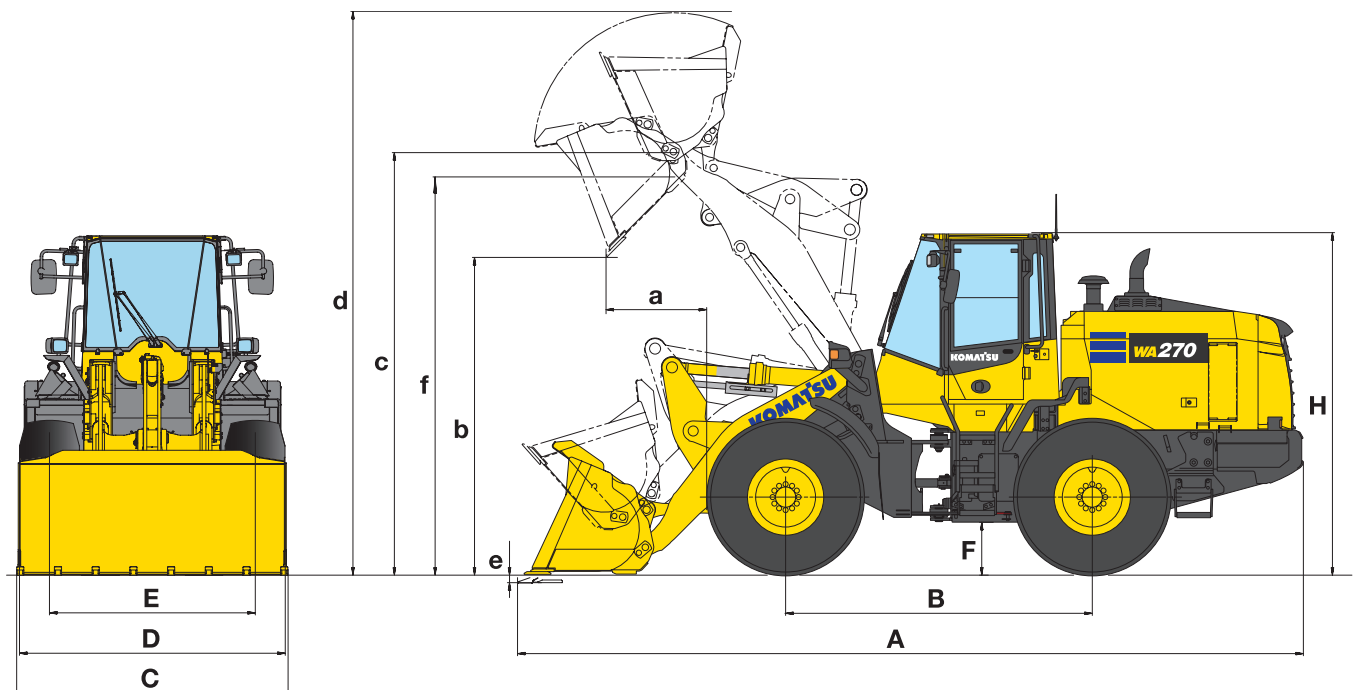

Bucket with raised bottom				Change in data caused by:			
w. teeth	w. BOC	w. teeth	w. BOC	High-lift equipment	Tyres 17.5R25 GP-2B L2	Tyres 20.5R25 XMINE L5	w/o add. counterweight
direct	direct	QC	QC				
2.2	2.3	2.2	2.3				
C14	C15	C84	C85				
2.05	1.95	1.90	1.80	- 0.4			- 0.1
1123	1132	1068	1077				
10266	10192	9492	9423	- 2020	- 330	+ 680	- 515
8938	8872	8222	8161	- 1810	- 230	+ 500	- 440
127	120	106	101	+ 5			
119	119	118	119	- 30			
13089	13098	13420	13429	+ 110	- 200	+ 450	- 280
5240	5240	5240	5240				
5878	5825	5944	5890	+ 190			
1133	1000	1292	1158	+ 105	+ 70	- 20	
2773	2895	2629	2750	+ 425	- 75	+ 25	
3965	3965	3965	3965	+ 430			
5185	5185	5360	5360	+ 430			
125	150	115	140	+ 125			
3680	3680	3680	3680	+ 420			
7658	7497	7865	7704	+ 495			
2900	2900	2900	2900				
2550	2540	2550	2540				
2470	2470	2470	2470		- 75		
1930	1930	1930	1930				
465	465	465	465				
3200	3200	3200	3200		- 75	+ 25	

Typical material density – loose (in kg/m³)

Basalt	1960	Gravel, unscreened	1930	Sandstone	1510
Bauxite, kaolin	1420	Gravel, dry	1510	Slate	1250
Earth, dry, ex store	1510	Gravel, dry, 6 - 50 mm	1690	Slag, broken	1750
Earth, wet, excavated	1600	Gravel, wet, 6 - 50 mm	2020	Stone, crushed	1600
Gypsum, broken	1810	Sand, dry, loose	1420	Clay, natural	1660
Gypsum, crushed	1600	Sand, damp	1690	Clay, dry	1480
Granite, broken	1660	Sand, wet	1840	Clay, wet	1660
Limestone, broken	1540	Sand and clay, loose	1600	Clay and gravel, dry	1420
Limestone, crushed	1540	Sand and gravel, dry	1720	Clay and gravel, wet	1540

Dimensions and performance figures

Fork tines

		High-lift	
Sales code		C57	C57
Fork tine length	mm	1200	1200
A Max. reach at ground level	mm	1025	1525
B Max. reach	mm	1690	2085
C Max. reach at max. stacking height	mm	780	890
a Max. height fork-carrier	mm	4760	5185
b Hinge pin height	mm	3965	4395
c Max. stacking height	mm	3820	4250
d Height of forks at max. reach	mm	1820	1820
Max. tipping load, straight	kg	7420	6290
Max. tipping load, articulated	kg	6475	5450
Max. payload as per EN 474-3, 80%	kg	5180	4360
Max. payload as per EN 474-3, 60%	kg	3900	3270
Weight in working order with fork tines	kg	12915	13025

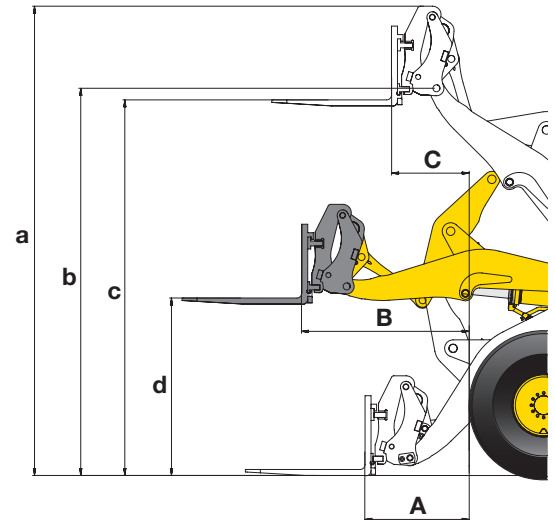

Light material bucket

		High-lift	
Sales code		Q364	Q854
Bucket capacity (heaped, ISO 7546)	m ³	3.5	3.5
Tube style spill guard		without	with
Bucket mount (direct/quick-coupler)		QC	QC
Material density	t/m ³	1.0	0.8
Bucket width	mm	2550	2550
Bucket weight	kg	1190	1190
A Reach at 45°	mm	1335	1435
a Height top edge of bucket	mm	5610	6040
b Hinge pin height	mm	3965	4395
c Max. loading height at 45°	mm	3620	4050
d Dump height at 45°	mm	2460	2890
Static tipping load, 40° articulated (L3 tyres)	kg	7920	6185
Static tipping load, 40° articulated (L5 tyres)	kg	8300	6500
Operating weight (L3 tyres)	kg	13465	13570
Operating weight (L5 tyres)	kg	14115	14220

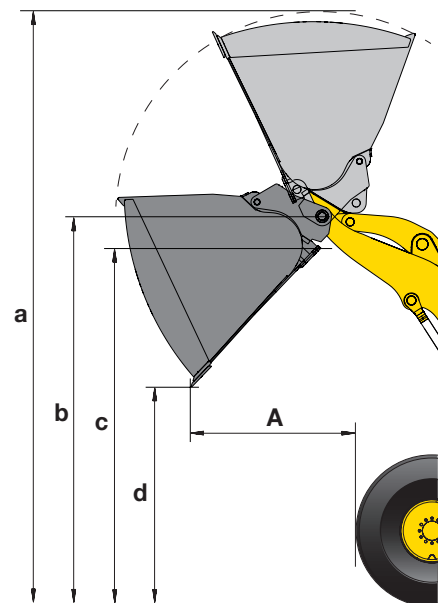

Typical material density – loose (in kg/m³)

Basalt	1960	Gravel, unscreened	1930	Sandstone	1510
Bauxite, kaolin	1420	Gravel, dry	1510	Slate	1250
Earth, dry, ex store	1510	Gravel, dry, 6 - 50 mm	1690	Slag, broken	1750
Earth, wet, excavated	1600	Gravel, wet, 6 - 50 mm	2020	Stone, crushed	1600
Gypsum, broken	1810	Sand, dry, loose	1420	Clay, natural	1660
Gypsum, crushed	1600	Sand, damp	1690	Clay, dry	1480
Granite, broken	1660	Sand, wet	1840	Clay, wet	1660
Limestone, broken	1540	Sand and clay, loose	1600	Clay and gravel, dry	1420
Limestone, crushed	1540	Sand and gravel, dry	1720	Clay and gravel, wet	1540

All measurements with tyres 20.5 R25 and standard counterweight + additional side counterweights

High-dump bucket (waste handling)

		High-lift			
		Q863	Q864	Q865	Q866
Sales code		Q863	Q864	Q865	Q866
Bucket capacity (heaped, ISO 7546)	m ³	3.8	3.8	3.0	3.0
Tube style spill guard		with	with	with	with
Bucket mount (direct/quick-coupler)		direct	QC	direct	QC
Material density	t/m ³	0.8	0.8	0.8	0.8
Bucket width	mm	2550	2550	2550	2550
Bucket weight	kg	2180	1950	2020	1700
A Reach at 45°	mm	1545	1590	1545	1625
a Height top edge of bucket	mm	6225	6390	6575	6335
b Max. loading height at 45°	mm	4480	4640	4920	4700
c Dump height at 45°	mm	4255	4405	4790	4410
Static tipping load, 40° articulated (L3 tyres)	kg	7365	6615	5775	5650
Static tipping load, 40° articulated (L5 tyres)	kg	7745	5965	6090	5955
Operating weight (L3 tyres)	kg	14005	14225	14015	13895
Operating weight (L5 tyres)	kg	14720	14875	14665	14545

Type B, dump cylinders located outside bucket

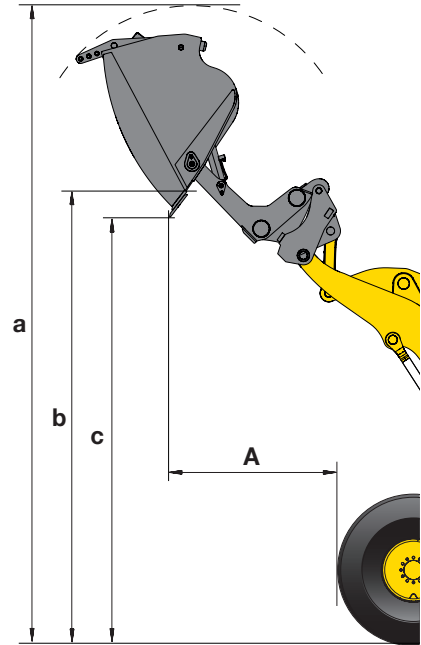

High-dump bucket (bulk materials)

		High-lift			
		Q413	Q414	Q461	Q462
Sales code		Q413	Q414	Q461	Q462
Bucket capacity (heaped, ISO 7546)	m ³	3.0	3.0	3.8	3.8
Tube style spill guard		without	without	without	without
Bucket mount (direct/quick-coupler)		direct	QC	direct	QC
Material density	t/m ³	1.1	1.1	0.6	0.6
Bucket width	mm	2550	2550	2550	2550
Bucket weight	kg	2020	1700	2180	1950
A Reach at 45°	mm	1445	1520	1645	1695
a Height top edge of bucket	mm	6145	5910	6655	6815
b Max. loading height at 45°	mm	4495	4270	4905	5060
c Dump height at 45°	mm	4365	3980	4680	4830
Static tipping load, 40° articulated (L3 tyres)	kg	7525	7000	5600	5050
Static tipping load, 40° articulated (L5 tyres)	kg	7900	7370	5920	5350
Operating weight (L3 tyres)	kg	13905	14175	14175	14330
Operating weight (L5 tyres)	kg	14560	14825	14825	14980

Type B, dump cylinders located outside bucket

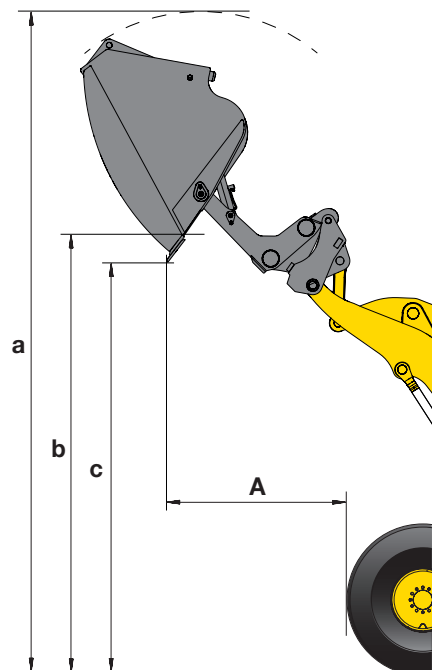

Typical material density (in ton/m³) for light material and high-dump buckets

Waste glass, fine	1.4	Waste paper, loose	0.6
Waste glass, coarse	1.0	Waste paper, processed	1.0
Compost, dry	0.8	Hard coal, high density	1.2
Compost, wet	1.0	Hard coal, low density	0.9
Wood chips, saw dust	0.5	Domestic waste, loose & dry	0.8

All measurements with tyres 20.5 R25 and standard counterweight + additional side counterweights

Standard and optional equipment

Engine

Komatsu SAA6D107E-3 turbocharged common rail direct injection diesel engine	●
EU Stage V compliant	●
Komatsu SmartLoader Logic	●
Adjustable idle shutdown	●
Auto-deceleration function	●
Fuel filter with water separator	●
Batteries 2 × 110 Ah / 2 × 12 V	●

Chassis and tyres

Heavy-duty axles	●
TPD-differential front and rear	●
Power train guard	●
Limited-slip differential (LSD) front and rear	○
Tyres 17.5 R25 L2	○
Tyres 20.5 R25 L2, L3, L4, L5	○
Agricultural tyres	○

Hydraulic system

3-spool main control valve including boom piping	●
PPC multi-function lever with electronic control for 3rd spool (EPC)	●
Automatic return-to-dig	●
Automatic boom kick-out	●
Biodegradable oil for hydraulic system	○

Transmission and brakes

Electronically controlled HST with 2-motor system	●
Speed control with fine adjustment in 1st speed range	●
Traction control system (K-TCS)	●
Fully hydraulic brake system	●
Combined brake/inching pedal	●
20 km/h limited hydrostatic driveline	○
25 km/h limited hydrostatic driveline	○

Cabin

Spacious double door driver's cab to DIN/ISO	●
ROPS/FOPS frame according to SAE	●
Heated, high back air suspension seat with lumbar support, console mounted height adjustable arm rests	●
Retractable seat belt	●
Automatic climate control system	●
Multi-function video compatible colour monitor with Equipment Management and Monitoring System (EMMS) and efficiency guidance	●
DAB+ digital radio w. auxiliary input (MP3 jack)	●
Hot and cool box	●
Heated rear window	●
Rear window wiper	●
Adjustable steering column	●
2 × 12 V power supply	●
Komatsu short lever steering (K-SLS)	○
3-point seat belt	○
Sun roller blind	○

Lighting system

2 halogen main headlights	●
2 spotlights at front and rear	●
Reversing light	●
Additional lights front and rear	○
LED working lights	○
Xenon working lights	○

Service and maintenance

Hydrostat-driven radiator fan with automatic reversing function	●
Wide core radiator	●
Komtrax – Komatsu wireless monitoring system (4G)	●
Komatsu Care – a maintenance program for Komatsu customers	●
Tool-set	●
Automatic central lubrication	●
Filling tool for central lubrication system	○
Turbo II air pre-cleaner, cyclone type	○

Safety equipment

Emergency steering system	●
Vandalism protection	●
Back-up alarm	●
Battery main switch	●
Handrails on left/right	●
Rear-view camera system	●
Front screen protective grid	○
Fire extinguisher	○
Beacon light	○
Roof rail	○
Rear view mirror, heated and remote control	○
Optical back-up alarm (strobe light)	○

Attachments

Hydraulic quick-coupler	○
High efficiency buckets with flat or raised bottom	○
High-dump buckets	○
Light material buckets	○
Waste handling buckets	○
Fork carrier and tines	○
Log grapple	○

Other equipment

PZ-kinematics: Z-bar boom with parallel movement	●
Counterweight	●
Electronically controlled load stabilizer (ECSS)	○
High-lift equipment w. add. counterweight	○
Additional side counterweights	○
Special custom colour	○
Anti-corrosion specification	○
Waste-handler specification	○
Agriculture specification	○
Cold area kit (engine and cab pre-heating)	○

Further equipment on request

- standard equipment
- optional equipment



A wide range of buckets and attachments is available. Your Komatsu distributor is ready to assist you with the selection of suitable options.

This specification sheet may contain attachments and optional equipment that are not available in your area. Please consult your local Komatsu distributor for those items you may require. Materials and specifications are subject to change without notice.

Your Komatsu partner:

KOMATSU

[komatsu.eu](https://www.komatsu.eu)

