

KOMATSU

WB97S-8

EU Stage IV Engine

4 WHEEL STEERING BACKHOE LOADER



WB97S

ENGINE POWER

75 kW / 101 HP @ 2.300 rpm

OPERATING WEIGHT

8.260 - 10.000 kg

BUCKET CAPACITY

1,1 m³ (Standard bucket)

Walk-Around

WB97S-8



ENGINE POWER

75 kW / 101 HP @ 2.300 rpm

OPERATING WEIGHT

8.260 - 10.000 kg

BUCKET CAPACITY

1,1 m³ (Standard bucket)



INCREASED EFFICIENCY AND ENVIRONMENTAL PERFORMANCE

Powerful and Environmentally Friendly

- EU Stage IV engine
- Up to 3% lower fuel consumption (vs. WB93R-5)
- Viscous fan clutch
- New monitoring system with Eco gauge
- Power and Eco mode improve fuel efficiency

Safety First

- Anti-burst valves for stabilizers, boom and arm (Standard)
- Emergency engine stop switch
- Seat belt caution indicator
- Unrivalled front visibility thanks to lateral exhaust pipe
- “Street mode” function

Total versatility

- 3 steering modes: 2WS, 4WS, crab
- Hydraulic side shift available
- Flip-over forks and pallet forks available
- Quick couplers for the front and rear buckets

Easy Maintenance

- Easy refilling from ground level for hydraulic oil, AdBlue® and fuel
- Maintenance information displayed on the monitor

KOMTRAX

- Komatsu Wireless Monitoring System
- 3G mobile communications



First-Class Comfort

- Multi-function monitor with high resolution 7” LCD color display
- Air-suspended operator seat (Standard)
- New ergonomic switch layout for the operator console
- Dial type fuel control and electric accelerator pedal
- New styling, state-of-the-art Komatsu design
- Hammer piping (Standard)

Powerful and Environmentally Friendly



Higher productivity

The Komatsu EU Stage IV compact engine featuring state-of-the-art technology delivers the highest efficiency in a small package. The aftertreatment system combines a Diesel Oxidation Catalyst (DOC) and Selective Catalytic Reduction (SCR). With ultra-low emissions, it provides a lower environmental impact and a superior performance to help reduce operating costs and lets the operator work in complete peace of mind.

Komatsu fuel-saving technology

The core of the Komatsu backhoe loader hydraulics is the Closed Load Sensing System (CLSS). Thanks to its variable flow, and together with the “Power” and “Economy” working modes, the integrated engine management, the viscous fan clutch and the eco gauge, the correct power is supplied to the machine when it is needed, and fuel consumption reduced by up to 3%.

Absolute control

The ‘Full Power Shift’ transmission is controlled by a twist grip lever, with automatic gear shifting as standard. A ‘kick-down’ function is also fitted as standard, allowing sequential shifting from 2nd gear to 1st by just pressing a switch. An automatic “Speed-up” function during loader operations easily releases the full hydraulic power of the WB97S-8.

WB97S-8

First-Class Comfort



Operator's environment

PPC servo-controls are standard for the front loader and backhoe. The dial type fuel control simplifies operation and engine speed adjustment. Air-suspended operator seat is standard, and switch layout for the operator console has a new ergonomic design.

New multi-function monitor with more information

A high-definition 7" LCD monitor provides excellent visibility. The high-definition LCD panel is less affected by the viewing angle and surrounding brightness, ensuring excellent visibility. Various alerts and machine information are displayed in a simple format. Useful information such as operation records, machine setting and maintenance data are also provided. The operator can easily navigate through screen pages with intuitive side buttons.



Convenient, ergonomic and precise control



Ergonomically designed switches



New 7" multi-function monitor

Maximized Efficiency



Loader

The front loader design ensures optimal parallel lifting; in addition, the divergent shape of the arm greatly improves visibility and provides excellent loading performance. The design of the backhoe features a clean and functional layout, with hydraulic piping and hoses along the boom. PPC servo-control is standard for the front loader.

S-shape backhoe

The rounded shape of the backhoe enhances the loading ability of the machine and its capacity to overcome obstacles, while ensuring a high breakout force. The telescopic arm significantly increases the machine's versatility.

Custom made

It's possible to choose from 3 steering modes: 2 wheel steering (standard operation), 4WS (agile and fast operation) and crab (confined areas). The many options offer a high level of customisation: hydraulic side-shift for the backhoe, LSS (Load Stabilizer System), radial tyres, offset boom and quick couplers are just a few.

Safety first

Unrivaled all round view

The wide round glass surface presents a highly increased visibility. The bonnet shape, the lateral exhaust pipe and the upper front window make it easy and safe to work with the front loader. When operating the backhoe excavator, the operator can easily open the single frame window and comfortably overlook the surrounding area.



Optimal jobsite safety

Safety features on the Komatsu WB97S-8 comply with the latest industry standards and work in synergy to minimise risks to people in and around the machine. Anti-burst valves are now included for backhoe operations and on stabilizers. A new "Engine shutdown" secondary switch, reachable from ground level, and a new optical seat belt alarm complete Komatsu's traditionally safe operator environment. For increased safety, the WB97S-8 includes a new "Travel Neutral" lock, "Street Mode" functions, and a new button for the horn on the backhoe PPC.



Secondary engine shut down switch

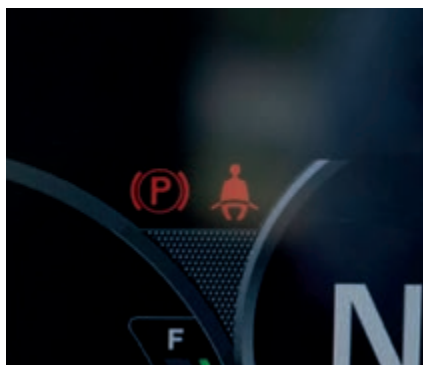

Seat belt caution



Anti-burst valves for stabilizers, boom and arm (Standard)

Easy Maintenance



Excellent serviceability

Komatsu designed the WB975-8 with an easy access to all service points. Routine maintenance and servicing are less likely to be skipped, which can mean a reduction of costly downtime later on. The radiator, aftercooler and oil cooler are made of aluminium to improve their efficiency and are mounted in parallel for quicker cleaning.

Flexible warranty

When you purchase Komatsu equipment, you gain access to a broad range of programmes and services that have been designed to help you get the most from your investment. For example, Komatsu's Flexible Warranty Programme provides a range of extended warranty options on the machine and its components. These can be chosen to meet your individual needs and activities. This programme is designed to help reduce total operating costs.



AdBlue®, fuel and hydraulic oil tank are easily accessible on the machine side and refilled by ground level, ensuring a fatigue less operation



Daily maintenance is enhanced thanks to the double position front opening and the check point position easily accessible on the left side



Maintenance information displayed on the monitor

KOMTRAX

The way to higher productivity

KOMTRAX uses the latest wireless monitoring technology. Compatible on PC, smartphone or tablet, it delivers insightful and cost saving information about your fleet and equipment, and offers a wealth of information to facilitate peak machine performance. By creating a tightly integrated web of support it allows proactive and preventive maintenance and helps to efficiently run a business.



Knowledge

You get quick answers to basic and critical questions about your machines – what they're doing, when they did it, where they're located, how they can be used more efficiently and when they need to be serviced. Performance data is relayed by wireless communication technology (satellite, GPRS or 3G depending on model) from the machine to a computer and to the local Komatsu distributor – who's readily available for expert analysis and feedback.

Power

The detailed information that KOMTRAX puts at your fingertips 24 hours a day, 7 days a week gives the power to make better daily and long-term strategic decisions – at no extra cost. Problems can be anticipated, maintenance schedules customised, downtime minimised and machines kept where they belong: working on the jobsite.

Convenience

KOMTRAX enables convenient fleet management on the web, wherever you are. Data is analysed and packaged specifically for effortless and intuitive viewing in maps, lists, graphs and charts. You can foresee eventual maintenance issues and required spare parts, and troubleshoot a problem before Komatsu technicians arrive on site.



Specifications

ENGINE

Model	Komatsu SAA4D99E-1
Type	Common rail direct injection, water-cooled, emissionised, turbocharged, after-cooled diesel
Engine power	
at rated engine speed	2.300 rpm
ISO 14396	75 kW / 101 HP
ISO 9249 (net engine power)	68,6 kW / 92,0 HP
Max. torque/engine speed	430 Nm/1.400 rpm
No. of cylinders	4
Bore x stroke	99 x 110 mm
Displacement	3,4 l
Cooling fan	Viscous fan clutch
Air-filter type	Dry type air cleaner with clogging indicator

CHASSIS AND TYRES

Frame	Reinforced and closed box structure
Axles	Heavy-duty axles
Final drive	Planetary gear in oil bath
Front axle total oscillation angle	16°
Max. front/rear axle static load rating	20.394 kg
Tyres (standard)	16.9 x 28 - 12 PR

HYDRAULIC SYSTEM

System	SynchroSystem with Speed-up function for loader arm
Type	CLSS. Closed-centre system with load sensing and pressure compensation valves
No. of working modes	2 (Power / Economy)
Hydraulic pump	Variable displacement axial pistons
Maximum pump flow	165 l/min
Working pressure (max.)	250 bar
Main valve	LIFD "Load Independent Flow Divider" modular type

CABIN

Two-door cab in conformity with ISO 3471 with ROPS (roll over protective structure) in conformity with SAE J1040c and FOPS (falling object protective structure) in conformity with ISO 3449

STEERING SYSTEM

System	4 wheel steering (3 modes) with electronic alignment
Turning radius (without using brakes)	
at bucket edge	4.886 mm
at corner of tyres	3.672 mm

TRANSMISSION

Electronically-controlled, four-wheel drive, "Full Power Shift" transmission. The control is automatic, with a knob used to select the direction of travel and the gears, at full power, without losing traction. Travelling speeds with 28" tyres:

Max. travel speeds (forwards/backwards)	
1. gear	6 km/h
2. gear	10 km/h
3. gear	21 km/h
4. gear	40 km/h

BRAKES

Oil immersed disc brakes are actuated by individual braking on each rear wheel with 2 separate pedals. Total integral braking on the 4 wheels is activated by operating the two pedals at the same time.

Parking brake (safety brake)	Caliper brake operated through a hand lever
------------------------------	---

OPERATING WEIGHT

Standard machine operating weight*	9.095 kg
Change in data caused by:	
Standard bucket	-290 kg
Standard arm	-230 kg
Pallet fork	-310 kg
Fork for 4x1 bucket	+290 kg
Air conditioner	+20 kg
Mech. quick-coupler (loader)	+140 kg
Mech. quick-coupler (backhoe)	+55 kg
Offset boom	-140 kg

* Including 4x1 bucket, telescopic arm, 600 mm backhoe bucket.
Max. permitted total weight 10.000 kg

SERVICE REFILL CAPACITIES

Engine oil	8 l
Cooling system	12 l
Fuel tank	135 l
Hydraulic oil tank	41,5 l
Hydraulic system	110 l
Axle front	11,8 l
Axle rear	11,8 l
Brake system	0,8 l
AdBlue® tank	13,5 l

ENVIRONMENT

Engine emissions	Fully complies with EU Stage IV exhaust emission regulations
Noise levels	Noise levels (external/internal) fully comply with 2000/14/EC Stage 2 and 2006/42/EC
Vibration levels (EN 12096:1997)	
Hand/arm	≤ 2,5 m/s ² (uncertainty K = 1,2 m/s ²)
Body	≤ 0,5 m/s ² (uncertainty K = 0,2 m/s ²)

LOADER

System	Loader arm with parallel movement
Standard bucket width	2.420 mm
Standard bucket capacity	1,1 m ³ (ISO 7546)
Standard bucket weight	458 kg
Lifting capacity	
at maximum height	3.825 daN (3.900 kg)
at ground level (ISO 14397)	5.200 daN (5.300 kg)
Breakout force (ISO 14397)	6.375 daN (6.500 kg)
4x1 bucket width	2.420 mm
4x1 bucket capacity	1,03 m ³ (ISO 7546)

BACKHOE

System	Reinforced structure, casted swing support and arm ends
Boom swing angle	180°
Bucket digging force (ISO 6015)	5.985 daN (6.100 kg)
Arm crowd force (ISO 6015)	3.925 daN (4.000 kg)
Outriggers	Vertical outriggers with adjustable wear device

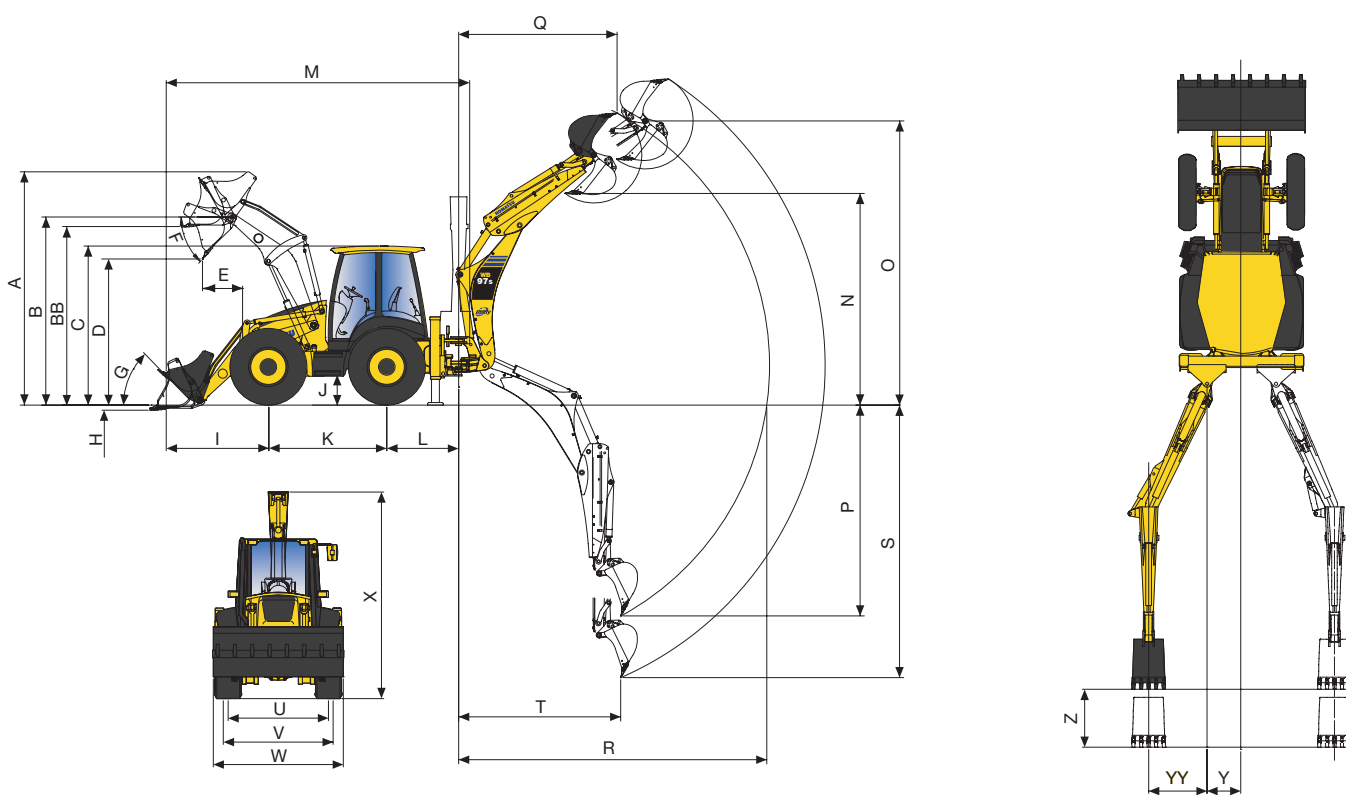

A	max height	4.405 mm
B	pin height	3.570 mm
BB	forks loading max height	3.225 mm
C	cab height	3.025 mm
D	max dumping height	2.925 mm
E	max dumping reach (45°)	515 mm
F	dumping angle	42°
G	rollback angle	44°
H	digging depth	145 mm
I	bucket reach (in transport)	2.170 mm
J	ground clearance	460 mm
K	wheel base	2.215 mm
L	backhoe swing centre distance	1.325 mm
M	transport length	5.850 mm
N	dumping height SAE	4.185 mm
	max dumping height	4.465 mm
	- with extended telescopic SAE	4.905 mm
	- with extended telescopic max	5.260 mm

O	max digging height	6.085 mm
	- with extended telescopic	6.785 mm
P	digging depth SAE	4.470 mm
	- with extended telescopic	5.720 mm
Q	reach at max height	3.050 mm
	- with extended telescopic	4.240 mm
R	max reach from swing centre	6.035 mm
	- with extended telescopic	7.175 mm
S	max digging depth	4.980 mm
	- with telescopic	6.170 mm
T	digging reach	1.965 mm
U	rear tread	1.950 mm
V	front tread	1.950 mm
W	overall width (with bucket)	2.440 mm
X	transport hoe height	3.910 mm
	- with telescopic	4.045 mm
Y	side shift	605 mm
YY	side shift with off-set	1.080 mm
Z	telescopic stroke	1.240 mm

When used in object handling operations, the backhoe portion must be equipped with hose burst valves (boom, arm and overload warning device) in compliance with EN474-4 and must operate in accordance with the related local regulations.

Standard and Optional Equipment

ENGINE

Komatsu SAA4D99E-1 water-cooled, 4-cycle direct injection diesel engine	●
EU Stage IV compliant	●
Dry type air cleaner with clogging indicator	●
Fuel control dial	●
Alternator 12 V / 120 A	●
Starter motor 12 V / 4,2 kW	●
Battery 12 V / 110 Ah	●
Air pre-cleaner, cyclone type	○

HYDRAULIC SYSTEM

2-working mode selection system; power mode, economy mode and Speed-up function for loader	●
PPC control lever for loader arm and bucket, with floating and "Return-To-Dig" function, front attachment control, transmission declutch control, differential locking	●
Hydraulic line for hammer till the arm end	●

SERVICE AND MAINTENANCE

Multi-function video compatible colour monitor with Equipment Management and Monitoring System (EMMS) and efficiency guidance	●
Battery main switch	●
KOMTRAX – Komatsu wireless monitoring system (3G)	●

CHASSIS AND TYRES

4 wheel drive	●
4 wheel steering (3 modes) with electronic alignment	●
Front mudguards	●
Tyres 16.9 × 24 - 12 PR	○
Tyres 16.9 × 28 - 12 PR	○
Tyres 440/80 R28	○

LIGHTING SYSTEM

Working lights on cab (2 front/2 rear)	●
LED working lights on cab (4 front/4 rear)	○

CABIN

ROPS (ISO 3471:2008, SAEJ/ISO3471) and FOPS level 2 (ISO 3449), two doors, fully opening rear window, front and rear window wipers, cup holder, sun visor	●
Adjustable suspension seat with seat belt	●
Monitor panel 7" colour display	●
4WS user friendly guidance system	●
12 Volt power supply	●
Beverage holder and magazine rack	●
Internal storage compartments (one lockable)	●
Adjustable steering column	●
Air conditioning	○
Radio	○

SAFETY EQUIPMENT

Travel acoustic alarm	●
Electric horn	●
Rear-view mirrors (left and right side, right rear)	●
Hose burst valves on backhoe boom/arm cylinders, and stabilizers	●
Overload warning device	●
Emergency engine stop switch	●
Seat belt caution indicator	●
Rotating beacon	●
Hose burst valves on loader arm cylinders	○

TRANSMISSION

Powershift transmission with 4 synchronised gears	●
Limited slip differential on both axles	●

OTHER EQUIPMENT

Standard colour scheme and decals	●
Parts book and operator manual	●
Hydraulic hand hammer circuit	○
Alternative control pattern ISO/SAE	○
Additional front counterweights (170 kg, 370 kg)	○
Rubber pads for stabilisers	○
Biodegradable hydraulic oil	○
TÜV + TBG version (40 km/h)	○
Special waxing	○

BACKHOE EQUIPMENT

PPC servo-controls	●
Electro-hydraulic backhoe boom lock	●
Backhoe swing transport lock	●
Electro-hydraulic backhoe slide frame release lock	●
PPC servo-controls for stabilisers	●
Hydraulic cushions	●
Hydraulic backhoe side shift	○
Telescopic arm	○
2-way circuit for attachments (auger, tilting bucket)	○

LOADER EQUIPMENT

PPC servo-controls	●
Speed-up function	●
Heavy-duty safety bar	●
Self-levelling	●
LSS (Load Stabiliser System)	○
Safety valve deactivation switch	○
Floating function	○

BACKHOE ATTACHMENTS

Bucket range (300 - 800 mm)	○
Ditch cleaning bucket (1.400 mm)	○
Bucket linkage with lifting hook	○

LOADER ATTACHMENTS

General purpose bucket w. teeth (1,1 m³)	○
4×1 bucket with pre-setting for flip-over forks and angle opening indicator (1,03 m³)	○
Heavy-duty 4×1 bucket (1,03 m³)	○
Bolt-on cutting edge	○
Cutting edge on teeth	○
Flip-over forks on 4×1 bucket	○
Forks (for quick-coupler)	○
Mechanical quick-coupler	○
Angle dozer blade (for quick-coupler)	○
Lifting hook bolted on upper side of 4×1 loader bucket, for object handling	○

The WB97S-8 is equipped in accordance with the safety regulations of the machinery directive 2006/42/EC and EN474.

- standard equipment
- optional equipment

Your Komatsu partner:

KOMATSU

**Komatsu Europe
International N.V.**

Mechelsesteenweg 586
B-1800 VILVOORDE (BELGIUM)
Tel. +32-2-255 24 11
Fax +32-2-252 19 81
www.komatsu.eu

WENSS08800 02/2020

KOMATSU is a trademark of Komatsu Ltd. Japan.